



turn to the experts 



# Super X/Xi SERIES VRF

Variable Refrigerant Flow Systems **2019**

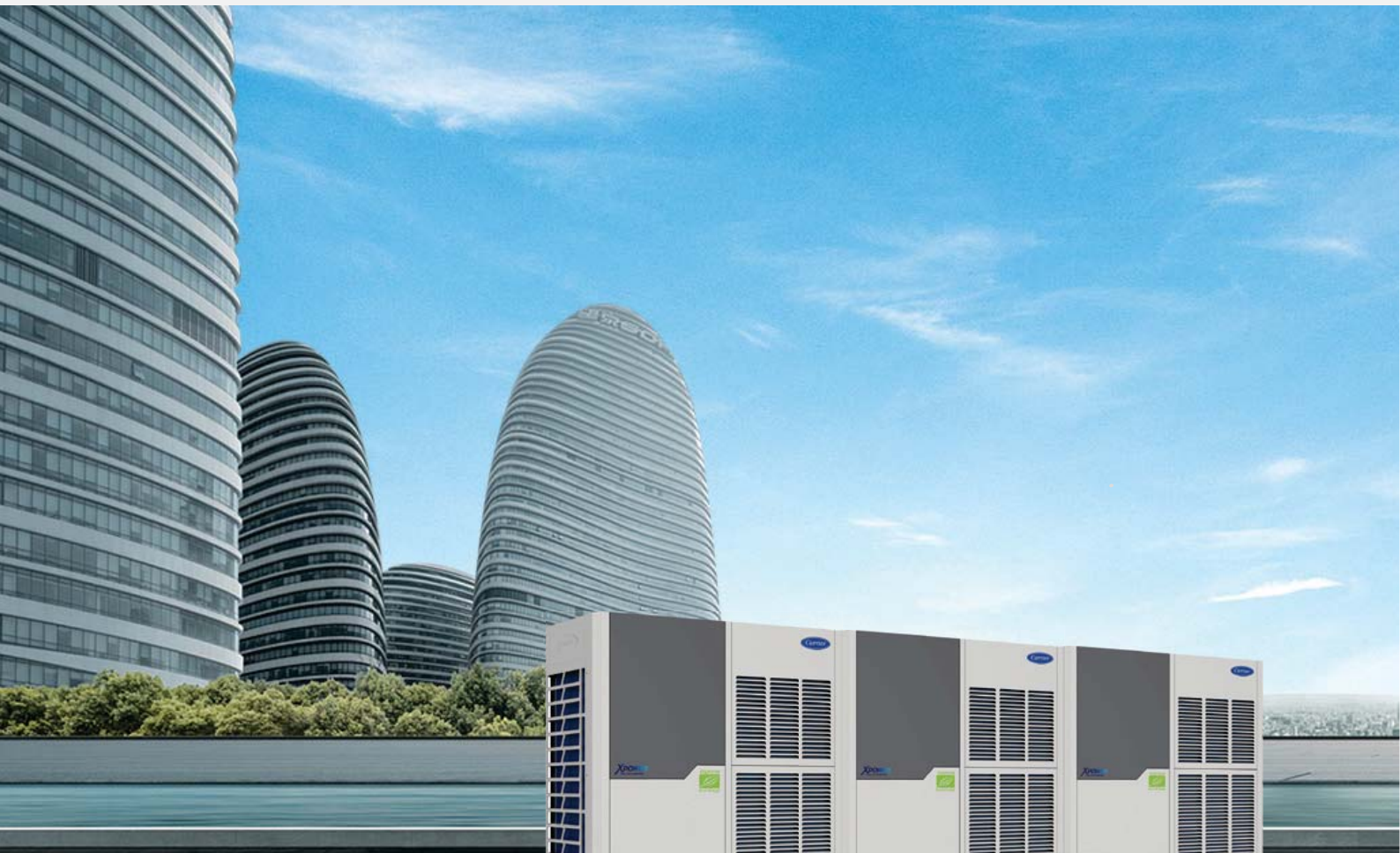



## OUTDOOR UNITS

---

XPower Super Xi (Stand Alone Units)	9
XPower Super X (Modular Units)	11

## INDOOR UNITS

---

One-way Cassette	36
Two-way Cassette	37
Compact Four-way Cassette	38
Four-way Cassette	39
Medium Static Pressure Duct	40
High Static Pressure Duct	41
Fresh Air Processing Unit	42
Wall Mounted Unit	43
Ceiling / Floor Unit	44
Floor Standing Unit	45
Console	47

## CONTROL SOLUTIONS

---

Wireless Remote Controllers	54
Wired Controllers	58
Centralized Controllers	62
Network Control System	68
BMS Gateways	74
Accessories	

## HRV

---

Heat Recovery Ventilator	94
--------------------------	----

# WEATHERMAKERS TO THE WORLD



*Willis H. Carrier*

THE INVENTOR OF MODERN  
AIR-CONDITIONING THAT CHANGED  
THE WAY WE LIVE, WORK AND PLAY.



# Carrier is a world leader in heating, air-conditioning and refrigeration solutions.

**Built on Willis Carrier's invention of modern air conditioning in 1902, Carrier is a world leader in heating, air-conditioning and refrigeration solutions. We constantly build upon our history of proven innovation with new products and services that improve global comfort and efficiency.**

Our innovations drive new industries and it is why our products and services are trusted in every corner of the world – and why you can feel good about trusting us in your corner of it.

## The invention that changed the world!

In 1902, Willis Carrier solved one of mankind's most elusive challenges by controlling the indoor environment through modern air conditioning. His invention enabled countless industries, promoting global productivity, health and personal comfort.

Today, Carrier innovations are found across the globe and in virtually every facet of daily life.

We create comfortable and productive environments, regardless of the climate. We safeguard the global food supply by preserving the quality and freshness of food and beverages. We ensure health and well-being by enabling the proper transport and delivery of vital medical supplies under exacting conditions. We provide solutions, services and education to lead the green building movement.

These mark just a handful of the ways Carrier works to make the world a better place to live, work and play.

#thankyouwilliscarrier

# CARRIER DELIVERS HIGH EFFICIENCY AND PERFORMANCE, **CERTIFIED BY EUROVENT!**

---

**Eurovent, the European Committee of Air Handling & Refrigeration Equipment Manufacturers, is the representative body for the European refrigeration, air-conditioning, air-handling, heating and ventilation industry and represents trade associations from European and non-European countries.**

Carrier actively participates in developing Eurovent certifications to help establish standards and achieve global compatibility.



\* Products that have been certified for their performance and efficiency by Eurovent will feature the Eurovent Certification logo.

## **What is Eurovent Certification?**

---

Eurovent Certification certifies the performance ratings of air-conditioning and refrigeration products according to European and international standards. The objective is to build up customer confidence by levelling the competitive playing field for all manufacturers and by increasing the integrity and accuracy of the industrial performance ratings.

When a product has been certified by Eurovent, the end users can be confident that their equipment will operate in accordance with the design specifications, the energy cost will be correctly stated and therefore the supplied product will correspond to the initial investment.

# Variable Refrigerant Flow Systems

---



turn to the experts 

# OUTDOOR UNIT LINEUP

---





# (Super Xi)

8 / 10 / 12HP  
with single fan



14 / 16 / 18HP  
with single fan







20 / 22HP  
with dual fans







24 / 26 / 28 / 30 / 32HP  
with dual fans



# OUTDOOR UNIT LINEUP

HP	8	10	12	14	16	18	20	22	24	26	28	30	32	
Appearance														
	(with single fan)	(with single fan)	(with single fan)	(with dual fans)										
	8	●												
	10		●											
12			●											
14				●										
16					●									
18						●								
20							●							
22								●						
24									●					
26										●				
28											●			
30												●		
32													●	
34			●					●						
36				●				●						
38					●			●						
40			●								●			
42							●	●						
44								● ●						
46								●	●					
48								●		●				
50								●			●			
52										● ●				

# (Super X)

HP	8	10	12	14	16	18	20	22	24	26	28	30	32	
Appearance	 (with single fan)		 (with single fan)		 (with dual fans)			 (with dual fans)						
										●	●			
											●●			
											●	●		●
54											●			
56											●●			
58											●	●		
60											●		●	
62												●	●	
64													●●	
66			●					●					●	
68				●				●					●	
70					●			●					●	
72			●								●		●	
74							●	●					●	
76								●●					●	
78								●	●				●	
80								●		●			●	
82								●			●		●	
84										●●			●	
86										●	●		●	
88											●●		●	
90											●	●	●	
92											●		●●	
94												●	●●	
96													●●●	

# INDOOR UNIT LINEUP

		kW	1.8	2.2	2.8	3.6	4.5	5.6	7.1
		Btu/h	5k	7k	9k	12k	15k	19k	24k
One-way Cassette			●	●	●	●	●	●	●
Two-way Cassette				●	●	●	●	●	●
Compact Four-way Cassette				●	●	●	●		
Four-way Cassette					●	●	●	●	●
Medium Static Pressure Duct				●	●	●	●	●	●
High Static Pressure Duct									●
Fresh Air Processing Unit									
Wall Mounted Unit				●	●	●	●	●	●
Ceiling / Floor Unit						●	●	●	●
Floor Standing Unit				●	●	●	●	●	●
Console				●	●	●	●		

8.0	9.0	10.0	11.2	12.5	14.0	16.0	20.0	25.0	28.0	40.0*	45.0*	56.0*
27k	30k	34k	38k	42k	48k	55k	68k	85k	96k	136k	154k	191k
●	●	●	●		●							
●	●		●		●							
●	●		●		●	●	●	●	●	●	●	●
				●	●		●	●	●			
●	●											
●	●		●		●							
●												

# 3 Unique Innovations

## Energy Management System (EMS)

- **Floating refrigerant temperature to balance comfort and efficiency**

The evaporating temperature (in cooling) and condensing temperature (in heating) are automatically adjusted according to both indoor and outdoor temperature to maximize the comfort and energy efficiency.

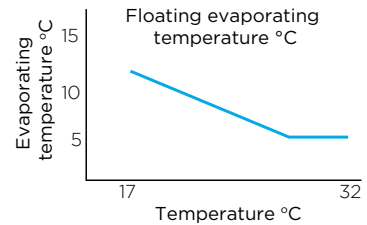

- **Output limitation during electricity supply restrictions**

With the integration of EMS, for projects with temporary electricity supply restrictions, Super X can be set to output 40-100% capacity.

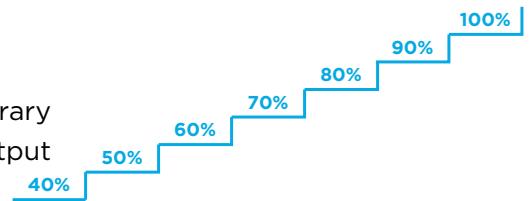

## Enhanced Vapor Injection (EVI) Compressor

Thanks to the vapor injection DC inverter compressor, the Super X VRF can run heating mode stably down to  $-23^{\circ}\text{C}$ , and the heating capacity can be improved greatly.

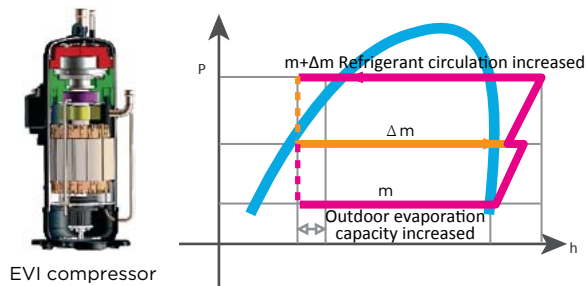

## Triple Configurations

Triple (local/remote/network) configurations greatly simplified installation, commissioning and servicing.

- Field local configuration achieves quick and easy on-site settings, simplifies installation and commissioning.
- System checking and settings also can be easily achieved via wired and centralized controller, making the configuration more flexible and convenient.
- A desktop or laptop PC can be used for browser-based access to achieve system configurations through IMM Pro gateway via a LAN connection.



# High Efficiency

## Plate Heat Exchanger (PHE) Subcooling

Plate Heat Exchanger as a secondary intercooler boosts up refrigerant subcooling and improves 10% energy efficiency.

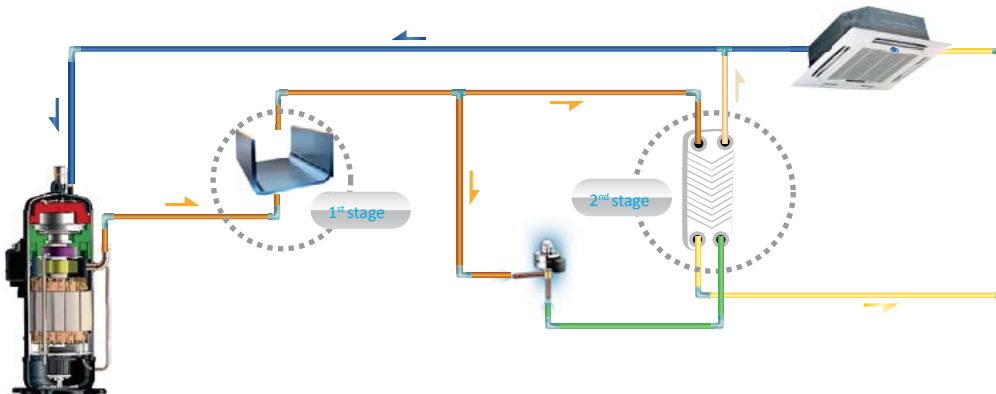

## High Efficiency G-Type Heat Exchanger

24-32HP units use a high efficiency 3-row G-type heat exchanger with a heat exchange area 1.5 times that of the 22HP unit. The 24-32HP units also use super big size fan which diameter is up to 750mm.

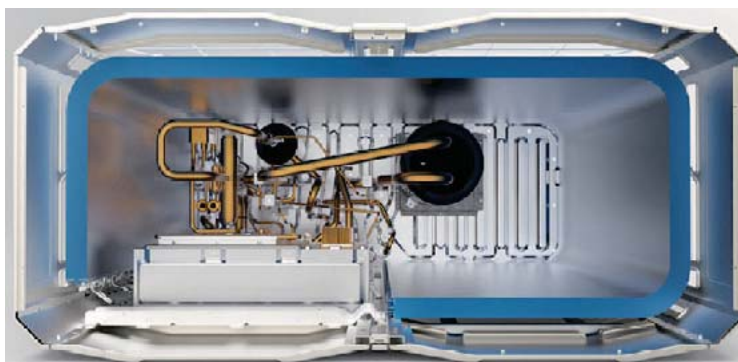

3-rows G-type heat exchanger

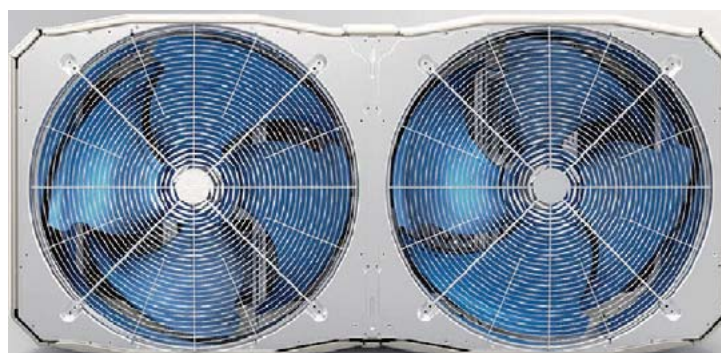

Super big size fan

# Wide Application Range

## Wide Capacity Range

Starting at 8HP, capacity increases in 2HP increments up to 96HP, which is the world's largest single-system VRF capacity.(Super X)

8/10/12HP  
(with single fan)



14/16HP  
(with single fan)



18/20/22HP  
(with dual fans)



24/26/28/30/32HP  
(with dual fans)



16-64HP



24-96HP



## Wide Operation Range

The Super X VRF can operate stably in a wide ambient temperature range: from -5°C to 48°C in cooling mode and from -23°C to 24°C in heating mode.

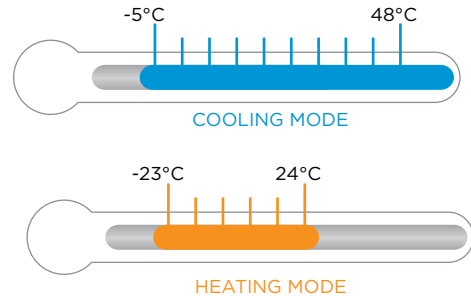

## Long Piping Capability

- Total piping length: 1000m
- Longest piping length - actual (equivalent): 175m (200m)
- Longest piping length after first branch: 90m
- Level difference between IDUs and ODU - ODU above (below): 90m (110m)
- Level difference between IDUs: 30m

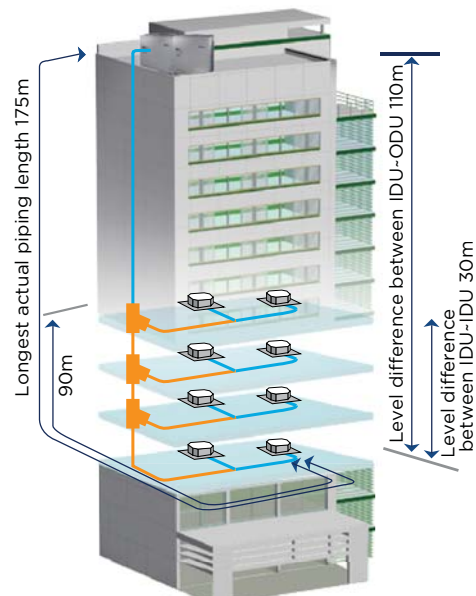



# High Reliability

## Duty Cycling

Duty cycling equalizes the running time of the outdoor units in a multiple-unit system and of the compressors in each unit, significantly extending compressor lifespan.(Super X)



1<sup>st</sup> cycle



2<sup>nd</sup> cycle



3<sup>rd</sup> cycle

## Precise Oil Control Technology

Four stages of oil control technology ensure all outdoor compressor oil is always kept at a safe level, eliminating any compressor oil shortage problems.

- Compressor internal oil separation.
- High-efficiency centrifugal oil separator (with separation efficiency of up to 99%) ensures that oil is separated from the discharge gas and returned to the compressors in a timely fashion.
- Oil balance pipes between compressors ensure even oil distribution to keep compressors running normally.
- Auto oil return program monitors the running time and system status to ensure reliable oil return.

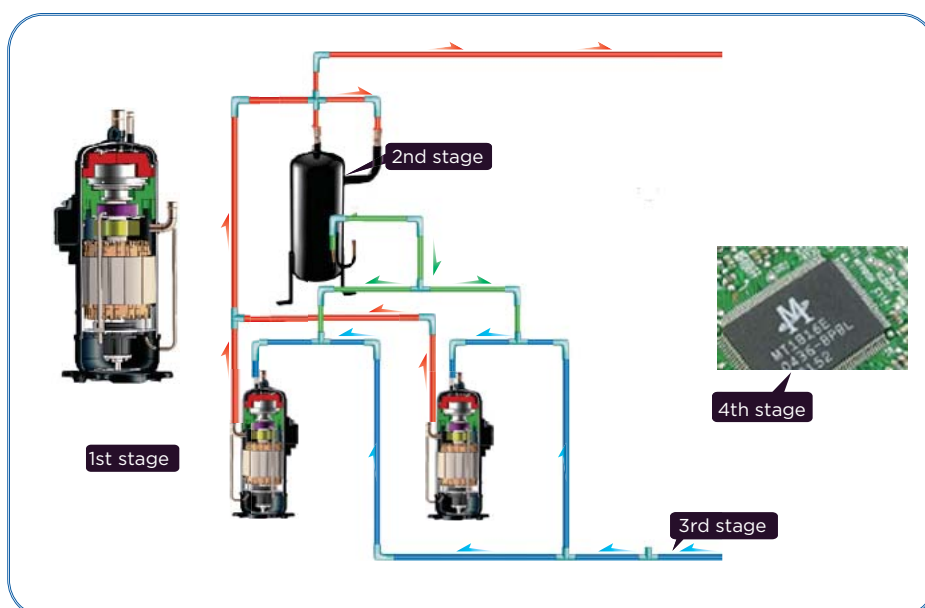

# High Reliability

## Backup Operation

In units with two compressors, if one compressor fails, the other compressor can run on its own for up to 4 days, allowing time for maintenance or repair whilst maintaining comfort.

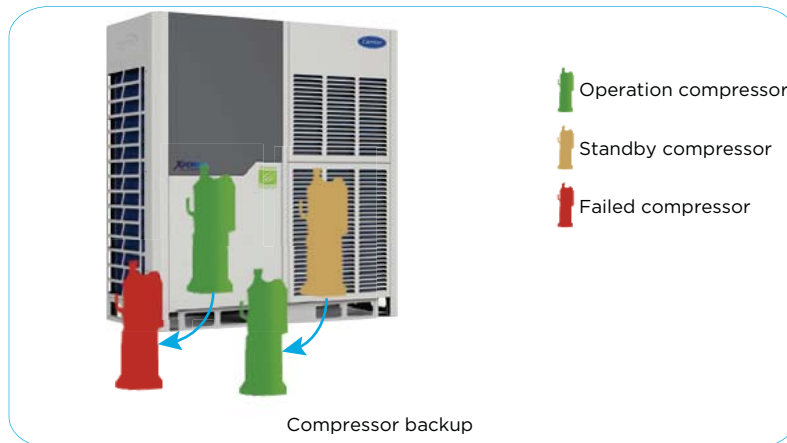

## Anti-corrosion Protection

Outdoor units are given anti-corrosion treatment for non-extreme conditions as standard and can also be customized with heavy anti-corrosion treatment on main components for surface protection against corrosive air, acid rain and saline air (for installations in coastal regions) to extend overall useful life. The integrity of the anti-corrosion treatment is ensured by subjecting major components and parts to salt mist testing, moisture and heating testing and light aging testing.

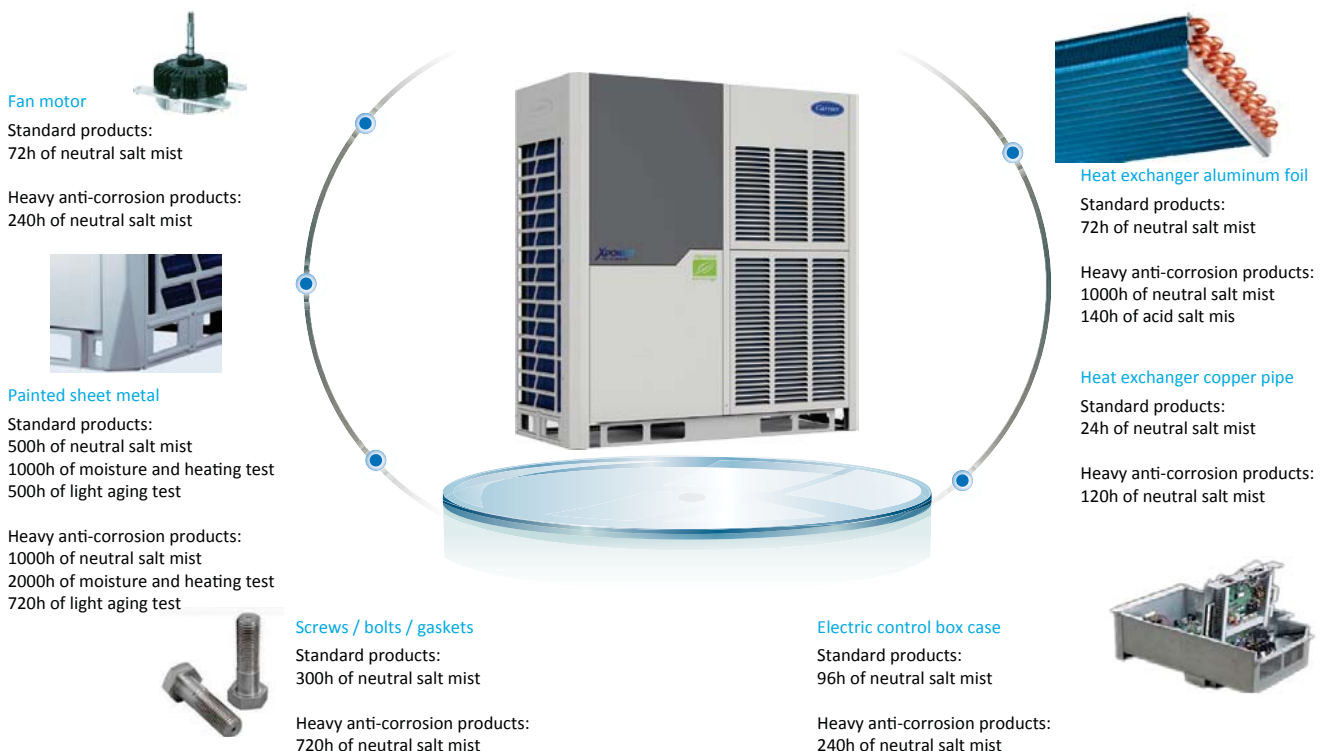

# High Reliability

## Refrigerant Cooling PCB

The Super X VRF uses refrigerant cooling technology to cool the electric control box. It decreases the average temperature of electrical control components by about 8 degrees, guaranteeing the stable and safe running of the control system.

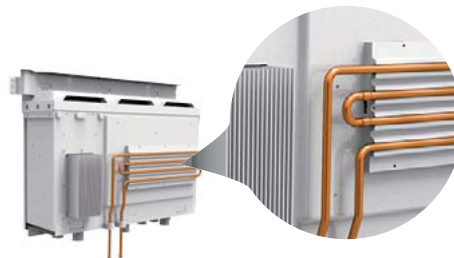

## Real-time Refrigerant Amount Monitoring

The temperature and pressure of refrigerant can be real-time monitored by the outdoor unit. When the level of refrigerant is too low or too high, this can cause damage to the unit and poor performance. Super X outdoor unit can detect excessive or insufficient amounts of refrigerant, to ensure consistent performance.

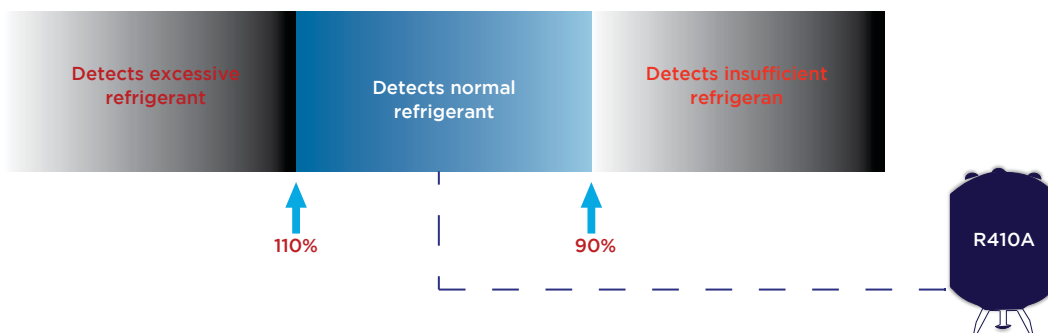

## Auto Snow-blowing Function\*

The innovatively designed auto snow-blowing function enables the outdoor unit to prevent the accumulation of snow by itself.

\*This function is available as a customization option.



## Dust-clean function\*

The innovatively designed dust-clean function enables the outdoor unit to prevent the dust by itself.

\*This function is available as a customization option.



# Enhanced Comfort

## Night Silent Mode

The night silent mode feature, which is easily configured on the outdoor unit's PCB, includes various scheduling options that can be used to reduce noise levels at times when low noise operation is required.

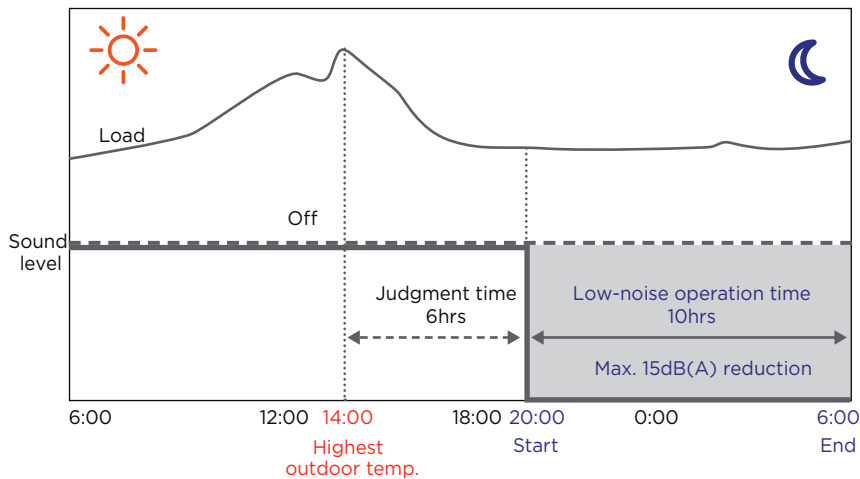

## Enhanced Heating Capacity

Heating capacity is 100% of rated capacity at ambient temperatures as low as  $-5^{\circ}\text{C}$  and 90% of rated capacity at  $-15^{\circ}\text{C}$ .

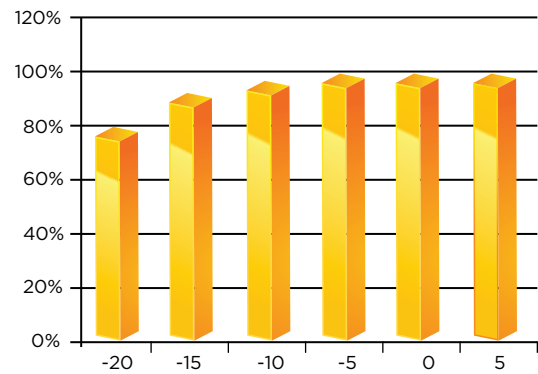

## Intelligent Defrosting Technology

The intelligent defrosting program calculates the time required for defrosting according to the actual system status, eliminating heat losses from unnecessary defrosting. A specialized defrosting valve reduces time required for defrosting to as little as four minutes.

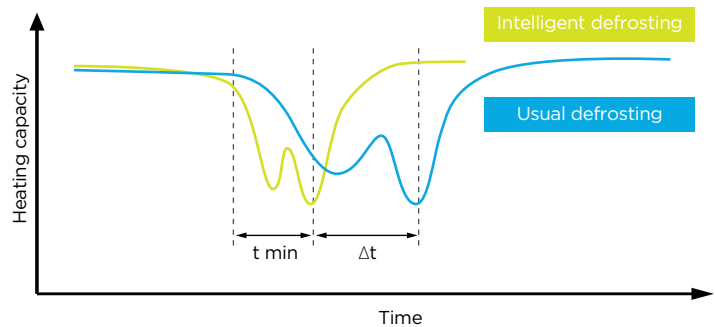

# Easy Installation and Service

## Non-polarized Communication Wiring\*

Only one chain of 2-core non-polarized shielded communication wiring required for indoor and outdoor unit communication.

\*In installations where relatively strong electromagnetic fields are present, 3-core shielded wiring should be used in order to prevent interference.

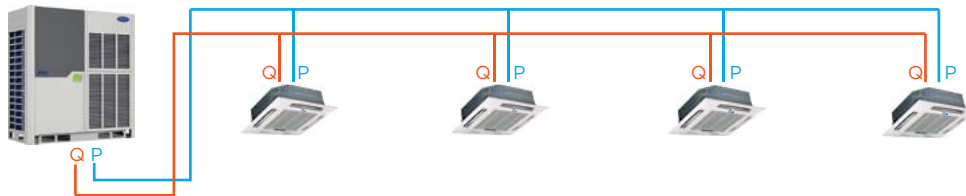

## Auto Addressing

Outdoor units can distribute addresses to indoor units automatically. Remote and wired controllers can be used to query or modify each indoor unit's address.

## Automatic Refrigerant Charging/Recycling Function\*

Automatic refrigerant charging and recycling make installation and service easier and more efficient.

\*This function is available as a customization option.

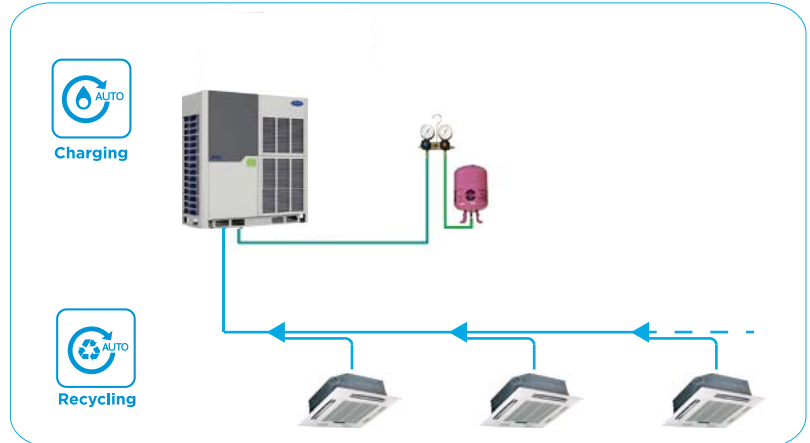

## Optional Multifunctional PCB

An optional multifunctional small PCB can be installed on the unit's side columns, enabling installation and service engineers to activate Auto-commissioning or check the operating status without removing the front panel. It can also perform automatic data backup of the last 30 minutes' operating record.



# Specifications(Super Xi)



Capacity		HP	8	10	12
Model			38VF008H119011-E	38VF010H119011-E	38VF012H119011-E
Power supply		V/Ph/Hz	380-415/3/50		
Cooling <sup>1</sup>	Capacity	kW	25.2	28	33.5
		kBtu/h	86	95.5	114.3
	Power input	kW	5.5	6.7	8.9
	EER			4.55	4.2
Heating <sup>2</sup>	Capacity	kW	25.2	1	33.5
		kBtu/h	86	95.5	114.3
	Power input	kW	4.8	5.5	7.6
	COP			5.2	5.1
Connected indoor unit		Total capacity	50-130% of outdoor unit capacity		
		Maximum quantity	13	16	20
Compressors		Type	DC inverter		
		Quantity	1		
Fan motors		Type	DC		
		Quantity	1		
		Max. ESP	Pa 20 Default; 60 Customization Option		
Refrigerant		Type	R410A		
		Factory charge	kg 11		
Pipe connections <sup>3</sup>		Liquid pipe	mm $\Phi$ 12.7		mm $\Phi$ 15.9
		Gas pipe	mm $\Phi$ 25.4		mm $\Phi$ 28.6
Airflow rate		m <sup>3</sup> /h	11000		
Sound pressure level <sup>4</sup>		dB(A)	58	58	60
Net dimensions (W×H×D)		mm	990×1635×790		
Packed dimensions (W×H×D)		mm	1090×1805×860		
Net weight		kg	227		
Gross weight		kg	242		
Ambient temp. operating range		Cooling	°C -5 to 48		
		Heating	°C -23 to 24		



Capacity		HP	14	16	18
Model			38VF014H119011-E	38VF016H119011-E	38VF018H119011-E
Power supply		V/Ph/Hz	380-415/3/50		
Cooling <sup>1</sup>	Capacity	kW	40	45	50
		kBtu/h	136.5	153.5	170.6
	Power input	kW	11	12.9	14.7
	EER			3.65	3.5
Heating <sup>2</sup>	Capacity	kW	40	45	50
		kBtu/h	136.5	153.5	170.6
	Power input	kW	9.3	10.7	12.2
	COP			4.3	4.2
Connected indoor unit		Total capacity	50-130% of outdoor unit capacity		
		Maximum quantity	23	26	29
Compressors		Type	DC inverter		
		Quantity	1		
Fan motors		Type	DC		
		Quantity	1		
		Max. ESP	Pa 20 Default; 60 Customization Option		
Refrigerant		Type	R410A		
		Factory charge	kg 13		
Pipe connections <sup>3</sup>		Liquid pipe	mm $\Phi$ 15.9		mm $\Phi$ 19.1
		Gas pipe	mm $\Phi$ 31.8		mm $\Phi$ 38.1
Airflow rate		m <sup>3</sup> /h	13000		
Sound pressure level <sup>4</sup>		dB(A)	60	61	62
Net dimensions (W×H×D)		mm	1340×1635×825		
Packed dimensions (W×H×D)		mm	1405×1805×910		
Net weight		kg	282		300
Gross weight		kg	311		329
Ambient temp. operating range		Cooling	°C -5 to 48		
		Heating	°C -23 to 24		

## Notes:

- Indoor temperature 27°C DB, 19°C WB; outdoor temperature 35°C DB; equivalent refrigerant piping length 7.5m with zero level difference.
- Indoor temperature 20°C DB; outdoor temperature 7°C DB, 6°C WB; equivalent refrigerant piping length 7.5m with zero level difference.
- Diameters given are those of the unit's stop valves.
- Sound pressure level is measured at a position 1m in front of the unit and 1.3m above the floor in a semi-anechoic chamber.

# Specifications(Super Xi)



Capacity		HP	20		22	
Model			38VF020H119011-E		38VF022H119011-E	
Power supply		V/Ph/Hz	380-415/3/50			
Cooling <sup>1</sup>	Capacity	kW	56		61.5	
		kBtu/h	191.1		209.8	
	Power input	kW	16		20.2	
	EER		3.5		3.05	
Heating <sup>2</sup>	Capacity	kW	56		61.5	
		kBtu/h	191.1		209.8	
	Power input	kW	13.8		17.6	
	COP		4.05		3.5	
Connected indoor unit	Total capacity		50-130% of outdoor unit capacity			
	Maximum quantity		33		36	
Compressors	Type		DC inverter			
	Quantity		2			
Fan motors	Type		DC			
	Quantity		2			
	Max. ESP	Pa	20 Default; 60 Customization Option			
Refrigerant	Type		R410A			
	Factory charge	kg	17			
Pipe connections <sup>3</sup>	Liquid pipe	mm	Φ19.1			
	Gas pipe	mm	Φ31.8			
Airflow rate		m <sup>3</sup> /h	17000			
Sound pressure level <sup>4</sup>		dB(A)	63			
Net dimensions (W×H×D)		mm	1340×1635×790			
Packed dimensions (W×H×D)		mm	1405×1805×910			
Net weight		kg	348			
Gross weight		kg	371			
Ambient temp. operating range	Cooling	°C	-5 to 48			
	Heating	°C	-23 to 24			



Capacity		HP	24	26	28	30	32
Model			38VF024H119011-E	38VF026H119011-E	38VF028H119011-E	38VF030H119011-E	38VF032H119011-E
Power supply		V/Ph/Hz	380-415/3/50				
Cooling <sup>1</sup>	Capacity	kW	67	73	78.5	85	90
		kBtu/h	228.6	249.1	267.8	290	307.1
	Power input	kW	21.6	21.6	24.9	28.3	32.1
	EER		3.1	3.4	3.15	3	2.8
Heating <sup>2</sup>	Capacity	kW	67	73	78.5	85	90
		kBtu/h	228.6	249.1	267.8	290	307.1
	Power input	kW	16.8	18.1	21.8	24.3	26.5
	COP		4	4.05	3.6	3.5	3.4
Connected indoor unit	Total capacity		50-130% of outdoor unit capacity				
	Maximum quantity		39	43	46	50	53
Compressors	Type		DC inverter				
	Quantity		2				
Fan motors	Type		DC				
	Quantity		2				
	Max. ESP	Pa	20 Default; 60 Customization Option				
Refrigerant	Type		R410A				
	Factory charge	kg	22			25	
Pipe connections <sup>3</sup>	Liquid pipe	mm	Φ19.1	Φ22.2			Φ38.1
	Gas pipe	mm	Φ31.8			24000	
Airflow rate		m <sup>3</sup> /h	25000				
Sound pressure level <sup>4</sup>		dB(A)	64				
Net dimensions (W×H×D)		mm	1730×1830×825				
Packed dimensions (W×H×D)		mm	1800×2000×910				
Net weight		kg	412	434	480		
Gross weight		kg	435	457	512		
Ambient temp. operating range	Cooling	°C	-5 to 48				
	Heating	°C	-23 to 24				

**Notes:**

- Indoor temperature 27°C DB, 19°C WB; outdoor temperature 35°C DB; equivalent refrigerant piping length 7.5m with zero level difference.
- Indoor temperature 20°C DB; outdoor temperature 7°C DB, 6°C WB; equivalent refrigerant piping length 7.5m with zero level difference.
- Diameters given are those of the unit's stop valves.
- Sound pressure level is measured at a position 1m in front of the unit and 1.3m above the floor in a semi-anechoic chamber.

# Specifications(Super X)



Capacity		HP	8	10	12	14
Model			38VF008H119016-E	38VF010H119016-E	38VF012H119016-E	38VF014H119016-E
Power supply		V/Ph/Hz	380-415/3/50			
Cooling <sup>1</sup>	Capacity	kW	25.2	28.0	33.5	40.0
		kBtu/h	86.0	95.5	114.3	136.5
	Power input	kW	5.3	6.3	8.7	9.9
	EER	kW/kW	4.75	4.45	3.85	4.05
Heating <sup>2</sup>	Capacity	kW	25.2	28.0	33.5	40.0
		kBtu/h	86.0	95.5	114.3	136.5
	Power input	kW	4.6	5.2	6.6	8.5
	COP	kW/kW	5.50	5.40	5.10	4.70
Connectable Indoor Unit	Total capacity		50-130% of outdoor unit capacity			
	Max. quantity		13	16	20	23
Compressors	Type		DC inverter			
	Quantity		1			
Fan motors	Type		DC			
	Quantity		1			
	Max. ESP	Pa	20 default; 60 customization option			
Refrigerant	Type		R410A			
	Factory charge	kg	11			
Pipe connections <sup>3</sup>	Liquid pipe	mm	Φ12.7		Φ15.9	
	Gas pipe	mm	Φ25.4		Φ28.6	
Airflow rate		m <sup>3</sup> /h	11000			13000
Sound pressure level <sup>4</sup>		dB(A)	58		60	
Net dimensions (WxHxD)		mm	990×1635×790			1340×1635×825
Packed dimensions (WxHxD)		mm	1090×1805×860			1405×1805×910
Net weight		kg	227			282
Gross weight		kg	242			311
Ambient temp. operating range	Cooling	°C	-5 to 48			
	Heating	°C	-23 to 24			



Capacity		HP	16	18	20	22	
Model			38VF016H119016-E	38VF018H119016-E	38VF020H119016-E	38VF022H119016-E	
Power supply		V/Ph/Hz	380-415/3/50				
Cooling <sup>1</sup>	Capacity	kW	45.0	50.0	56.0	61.5	
		kBtu/h	153.5	170.6	191.1	209.8	
	Power input	kW	12.0	12.5	15.1	18.4	
	EER	kW/kW	3.75	4.00	3.70	3.35	
Heating <sup>2</sup>	Capacity	kW	45.0	50.0	56.0	61.5	
		kBtu/h	153.5	170.6	191.1	209.8	
	Power input	kW	9.8	10.6	12.7	15.0	
	COP	kW/kW	4.60	4.70	4.40	4.10	
Connectable Indoor Unit	Total capacity		50-130% of outdoor unit capacity				
	Max. quantity		26	29	33	36	
Compressors	Type		DC inverter				
	Quantity		1				2
Fan motors	Type		DC				
	Quantity		1				2
	Max. ESP	Pa	20 default; 60 customization option				
Refrigerant	Type		R410A				
	Factory charge	kg	13				17
Pipe connections <sup>3</sup>	Liquid pipe	mm	Φ15.9		Φ19.1		
	Gas pipe	mm	Φ31.8		Φ31.8		
Airflow rate		m <sup>3</sup> /h	13000		17000		
Sound pressure level <sup>4</sup>		dB(A)	61		63		
Net dimensions (WxHxD)		mm	1340×1635×825		1340×1635×790		
Packed dimensions (WxHxD)		mm	1405×1805×910				
Net weight		kg	282		352		
Gross weight		kg	311		375		
Ambient temp. operating range	Cooling	°C	-5 to 48				
	Heating	°C	-23 to 24				

## Notes:

- Indoor temperature 27°C DB, 19°C WB; outdoor temperature 35°C DB; equivalent refrigerant piping length 7.5m with zero level difference.
- Indoor temperature 20°C DB; outdoor temperature 7°C DB, 6°C WB; equivalent refrigerant piping length 7.5m with zero level difference.
- Diameters given are those of the unit's stop valves.
- Sound pressure level is measured at a position 1m in front of the unit and 1.3m above the floor in a semi-anechoic chamber.



# Specifications(Super X)



Capacity		HP	24	26	28
Model			38VF024H119016-E	38VF026H119016-E	38VF028H119016-E
Power supply		V/Ph/Hz	380-415/3/50		
Cooling <sup>1</sup>	Capacity	kW	67.0	73.0	78.5
		kBtu/h	228.6	249.1	267.8
	Power input	kW	18.1	20.9	24.2
	EER	kW/kW	3.70	3.49	3.25
Heating <sup>2</sup>	Capacity	kW	67.0	73.0	78.5
		kBtu/h	228.6	249.1	267.8
	Power input	kW	14.9	17.6	20.7
	COP	kW/kW	4.50	4.15	3.80
Connectable Indoor Unit	Total capacity	50-130% of outdoor unit capacity			
	Max. quantity		39	43	46
Compressors	Type	DC inverter			
	Quantity	2			
Fan motors	Type	DC			
	Quantity	2			
	Max. ESP	Pa	20 default; 60 customization option		
Refrigerant	Type	R410A			
	Factory charge	kg	22		
Pipe connections <sup>3</sup>	Liquid pipe	mm	Φ19.1	Φ22.2	
	Gas pipe	mm	Φ31.8	Φ31.8	
Airflow rate		m <sup>3</sup> /h	25000		
Sound pressure level <sup>4</sup>		dB(A)	64		
Net dimensions (WxHxD)		mm	1730 × 1830 × 825		
Packed dimensions (WxHxD)		mm	1800×2000×910		
Net weight		kg	435		
Gross weight		kg	458		
Ambient temp. operating range	Cooling	°C	-5 to 48		
	Heating	°C	-23 to 24		



Capacity		HP	30	32
Model			38VF030H119016-E	38VF032H119016-E
Power supply		V/Ph/Hz	380-415/3/50	
Cooling <sup>1</sup>	Capacity	kW	85.0	90.0
		kBtu/h	290.0	307.1
	Power input	kW	27.4	31.0
	EER	kW/kW	3.10	2.90
Heating <sup>2</sup>	Capacity	kW	85.0	90.0
		kBtu/h	290.0	307.1
	Power input	kW	23.0	25.7
	COP	kW/kW	3.70	3.50
Connectable Indoor Unit	Total capacity	50-130% of outdoor unit capacity		
	Max. quantity		50	53
Compressors	Type	DC inverter		
	Quantity	2		
Fan motors	Type	DC		
	Quantity	2		
	Max. ESP	Pa	20 default; 60 customization option	
Refrigerant	Type	R410A		
	Factory charge	kg	25	
Pipe connections <sup>3</sup>	Liquid pipe	mm	Φ22.2	
	Gas pipe	mm	Φ38.1	
Airflow rate		m <sup>3</sup> /h	24000	
Sound pressure level <sup>4</sup>		dB(A)	64	
Net dimensions (WxHxD)		mm	1730 × 1830 × 825	
Packed dimensions (WxHxD)		mm	1800×2000×910	
Net weight		kg	480	
Gross weight		kg	512	
Ambient temp. operating range	Cooling	°C	-5 to 48	
	Heating	°C	-23 to 24	

**Notes:**

- Indoor temperature 27°C DB, 19°C WB; outdoor temperature 35°C DB; equivalent refrigerant piping length 7.5m with zero level difference.
- Indoor temperature 20°C DB; outdoor temperature 7°C DB, 6°C WB; equivalent refrigerant piping length 7.5m with zero level difference.
- Diameters given are those of the unit's stop valves.
- Sound pressure level is measured at a position 1m in front of the unit and 1.3m above the floor in a semi-anechoic chamber.

# Specifications(Super X)



Capacity		HP	34	36	38	40
Model			38VF034H119016-E	38VF036H119016-E	38VF038H119016-E	38VF040H119016-E
Combination type			12HP+22HP	14HP+22HP	16HP+22HP	12HP+28HP
Power supply		V/Ph/Hz	380-415/3/50			
Cooling <sup>1</sup>	Capacity	kW	95.0	101.5	106.5	112.0
		kBtu/h	324.1	346.3	363.4	382.1
	Power input	kW	27.1	28.2	30.4	32.9
	EER	kW/kW	3.51	3.59	3.51	3.41
Heating <sup>2</sup>	Capacity	kW	95.0	101.5	106.5	112.0
		kBtu/h	324.1	346.3	363.4	382.1
	Power input	kW	21.6	23.5	24.8	27.2
	COP	kW/kW	4.40	4.32	4.30	4.11
Connectable Indoor Unit	Total capacity		50-130% of outdoor unit capacity			
	Max. quantity		56	59	63	64
Compressors	Type		DC inverter			
	Quantity		3			
Fan motors	Type		DC			
	Quantity		3			
	Max. ESP	Pa	20 default; 60 customization option			
Refrigerant	Type		R410A			
	Factory charge	kg	11+17	13+17		11+22
Pipe connections <sup>3</sup>	Liquid pipe	mm	Φ19.1		Φ19.1	
	Gas pipe	mm	Φ31.8		Φ38.1	
Airflow rate		m <sup>3</sup> /h	28000	30000		36000
Sound pressure level <sup>4</sup>		dB(A)	65			
Net dimensions (WxHxD)		mm	(990×1635×790)+(1340×1635×790)	(1340×1635×825)+(1340×1635×790)		(990×1635×790)+(1730×1830×825)
Packed dimensions (WxHxD)		mm	(1090×1805×860)+(1405×1805×910)	(1405×1805×910)×2		(1090×1805×860)+(1800×2000×910)
Net weight		kg	227+352	282+352		227+435
Gross weight		kg	242+375	311+375		242+458
Ambient temp. operating range	Cooling	°C	-5 to 48			
	Heating	°C	-23 to 24			



Capacity		HP	42	44	46	48
Model			38VF042H119016-E	38VF044H119016-E	38VF046H119016-E	38VF048H119016-E
Combination type			20HP+22HP	22HP+22HP	22HP+24HP	22HP+26HP
Power supply		V/Ph/Hz	380-415/3/50			
Cooling <sup>1</sup>	Capacity	kW	117.5	123.0	128.5	134.5
		kBtu/h	400.9	419.7	438.4	458.9
	Power input	kW	33.5	36.7	36.5	39.3
	EER	kW/kW	3.51	3.35	3.52	3.43
Heating <sup>2</sup>	Capacity	kW	117.5	123.0	128.5	134.5
		kBtu/h	400.9	419.7	438.4	458.9
	Power input	kW	27.7	30.0	29.9	32.6
	COP	kW/kW	4.24	4.10	4.30	4.13
Connectable Indoor Unit	Total capacity		50-130% of outdoor unit capacity			
	Max. quantity		64			
Compressors	Type		DC inverter			
	Quantity		4			
Fan motors	Type		DC			
	Quantity		4			
	Max. ESP	Pa	20 default; 60 customization option			
Refrigerant	Type		R410A			
	Factory charge	kg	17×2			17+22
Pipe connections <sup>3</sup>	Liquid pipe	mm		Φ19.1		
	Gas pipe	mm		Φ38.1		
Airflow rate		m <sup>3</sup> /h	34000			42000
Sound pressure level <sup>4</sup>		dB(A)	66			
Net dimensions (WxHxD)		mm	(1340×1635×790)×2		(1340×1635×790)+(1730×1830×825)	
Packed dimensions (WxHxD)		mm	(1405×1805×910)×2		(1405×1805×910)+(1800×2000×910)	
Net weight		kg	352×2		352+435	
Gross weight		kg	375×2		375+458	
Ambient temp. operating range	Cooling	°C	-5 to 48			
	Heating	°C	-23 to 24			

## Notes:

- Indoor temperature 27°C DB, 19°C WB; outdoor temperature 35°C DB; equivalent refrigerant piping length 7.5m with zero level difference.
- Indoor temperature 20°C DB; outdoor temperature 7°C DB, 6°C WB; equivalent refrigerant piping length 7.5m with zero level difference.
- Diameters given are those for the pipe connecting the outdoor unit combination to the first indoor branch joint for systems with total equivalent liquid piping lengths of less than 90m. For systems with total equivalent liquid piping lengths of 90m or longer, please refer to the V6 Series Engineering Data Book for connection piping diameters.
- Sound pressure level is measured at a position 1m in front of the unit and 1.3m above the floor in a semi-anechoic chamber.

# Specifications(Super X)



Capacity		HP	50	52	54	56
Model			38VF050H119016-E	38VF052H119016-E	38VF054H119016-E	38VF056H119016-E
Combination type			22HP+28HP	26HP+26HP	26HP+28HP	28HP+28HP
Power supply		V/Ph/Hz	380-415/3/50			
Cooling <sup>1</sup>	Capacity	kW	140.0	146.0	151.5	157.0
		kBtu/h	477.7	498.2	516.9	535.7
	Power input	kW	42.5	41.8	45.1	48.3
	EER	kW/kW	3.29	3.49	3.36	3.25
Heating <sup>2</sup>	Capacity	kW	140.0	146.0	151.5	157.0
		kBtu/h	477.7	498.2	516.9	535.7
	Power input	kW	35.7	35.2	38.3	41.3
	COP	kW/kW	3.93	4.15	3.96	3.80
Connectable Indoor Unit	Total capacity		50-130% of outdoor unit capacity			
	Max. quantity		64			
Compressors	Type		DC inverter			
	Quantity		4			
Fan motors	Type		DC			
	Quantity		4			
	Max. ESP	Pa	20 default; 60 customization option			
Refrigerant	Type		R410A			
	Factory charge	kg	17+22		22×2	
Pipe connections <sup>3</sup>	Liquid pipe	mm		Φ19.1		Φ19.1
	Gas pipe	mm		Φ38.1		Φ41.3
Airflow rate		m <sup>3</sup> /h	42000		50000	
Sound pressure level <sup>4</sup>		dB(A)	66			
Net dimensions (WxHxD)		mm	(1340×1635×790)+(1730×1830×825)		(1730×1830×825)×2	
Packed dimensions (WxHxD)		mm	(1405×1805×910)+(1800×2000×910)		(1800×2000×910)×2	
Net weight		kg	352+435		435×2	
Gross weight		kg	375+458		458×2	
Ambient temp. operating range	Cooling	°C	-5 to 48			
	Heating	°C	-23 to 24			



Capacity		HP	58	60	62	64
Model			38VF058H119016-E	38VF060H119016-E	38VF062H119016-E	38VF064H119016-E
Combination type			28HP+30HP	28HP+32HP	30HP+32HP	32HP+32HP
Power supply		V/Ph/Hz	380-415/3/50			
Cooling <sup>1</sup>	Capacity	kW	163.5	168.5	175.0	180.0
		kBtu/h	557.9	574.9	597.1	614.2
	Power input	kW	51.6	55.2	58.5	62.1
	EER	kW/kW	3.17	3.05	2.99	2.90
Heating <sup>2</sup>	Capacity	kW	163.5	168.5	175.0	180.0
		kBtu/h	557.9	574.9	597.1	614.2
	Power input	kW	43.6	46.4	48.7	51.4
	COP	kW/kW	3.75	3.63	3.59	3.50
Connectable Indoor Unit	Total capacity		50-130% of outdoor unit capacity			
	Max. quantity		64			
Compressors	Type		DC inverter			
	Quantity		4			
Fan motors	Type		DC			
	Quantity		4			
	Max. ESP	Pa	20 default; 60 customization option			
Refrigerant	Type		R410A			
	Factory charge	kg	22+25		25×2	
Pipe connections <sup>3</sup>	Liquid pipe	mm		Φ19.1		
	Gas pipe	mm		Φ41.3		
Airflow rate		m <sup>3</sup> /h	49000		48000	
Sound pressure level <sup>4</sup>		dB(A)	66			
Net dimensions (WxHxD)		mm	(1730×1830×825)×2			
Packed dimensions (WxHxD)		mm	(1800×2000×910)×2			
Net weight		kg	435+480		480×2	
Gross weight		kg	458+512		512×2	
Ambient temp. operating range	Cooling	°C	-5 to 48			
	Heating	°C	-23 to 24			

**Notes:**

- Indoor temperature 27°C DB, 19°C WB; outdoor temperature 35°C DB; equivalent refrigerant piping length 7.5m with zero level difference.
- Indoor temperature 20°C DB; outdoor temperature 7°C DB, 6°C WB; equivalent refrigerant piping length 7.5m with zero level difference.
- Diameters given are those for the pipe connecting the outdoor unit combination to the first indoor branch joint for systems with total equivalent liquid piping lengths of less than 90m. For systems with total equivalent liquid piping lengths of 90m or longer, please refer to the V6 Series Engineering Data Book for connection piping diameters.
- Sound pressure level is measured at a position 1m in front of the unit and 1.3m above the floor in a semi-anechoic chamber.

# Specifications(Super X)



Capacity		HP	66	68	70	72
Model			38VF066H119016-E	38VF068H119016-E	38VF070H119016-E	38VF072H119016-E
Combination type			12HP+22HP+32HP	14HP+22HP+32HP	16HP+22HP+32HP	12HP+28HP+32HP
Power supply		V/Ph/Hz	380-415/3/50			
Cooling <sup>1</sup>	Capacity	kW	185.0	191.5	196.5	202.0
		kBtu/h	631.2	653.4	670.5	689.2
	Power input	kW	58.1	59.3	61.4	63.9
		EER	kW/kW	3.18	3.23	3.20
Heating <sup>2</sup>	Capacity	kW	185.0	191.5	196.5	202.0
		kBtu/h	631.2	653.4	670.5	689.2
	Power input	kW	47.3	49.2	50.5	52.9
		COP	kW/kW	3.91	3.89	3.89
Connectable Indoor Unit	Total capacity		50-130% of outdoor unit capacity			
	Max. quantity		64			
Compressors	Type		DC inverter			
	Quantity		5			
Fan motors	Type		DC			
	Quantity		5			
	Max. ESP	Pa	20 default; 60 customization option			
Refrigerant	Type		R410A			
	Factory charge	kg	11+17+25	13+17+25	11+22+25	11+22+25
Pipe connections <sup>3</sup>	Liquid pipe	mm	Φ19.1		Φ22.2	
	Gas pipe	mm	Φ41.3		Φ44.5	
Airflow rate		m <sup>3</sup> /h	52000	54000	60000	60000
Sound pressure level <sup>4</sup>		dB(A)	67			
Net dimensions (WxHxD)		mm	(990×1635×790)+(1340×1635×790)+(1730×1830×825)	(1340×1635×825)+(1340×1635×790)+(1730×1830×825)	(990×1635×790)+(1730×1830×825)×2	(1090×1805×860)+(1800×2000×910)×2
Packed dimensions (WxHxD)		mm	(1090×1805×860)+(1405×1805×910)+(1800×2000×910)	(1405×1805×910)×2+(1800×2000×910)	(1090×1805×860)+(1800×2000×910)×2	(1800×2000×910)×2
Net weight		kg	227+348+475	277+348+475	227+430+475	227+430+475
Gross weight		kg	242+368+507	304+368+507	242+453+507	242+453+507
Ambient temp. operating range	Cooling	°C	-5 to 48			
	Heating	°C	-23 to 24			



Capacity		HP	74	76	78	80
Model			38VF074H119016-E	38VF076H119016-E	38VF078H119016-E	38VF080H119016-E
Combination type			20HP+22HP+32HP	22HP+22HP+32HP	22HP+24HP+32HP	22HP+26HP+32HP
Power supply		V/Ph/Hz	380-415/3/50			
Cooling <sup>1</sup>	Capacity	kW	207.5	213.0	218.5	224.5
		kBtu/h	708.0	726.8	745.5	766.0
	Power input	kW	64.5	67.8	67.5	70.3
		EER	kW/kW	3.22	3.14	3.24
Heating <sup>2</sup>	Capacity	kW	207.5	213.0	218.5	224.5
		kBtu/h	708.0	726.8	745.5	766.0
	Power input	kW	53.4	55.7	55.6	58.3
		COP	kW/kW	3.88	3.82	3.93
Connectable Indoor Unit	Total capacity		50-130% of outdoor unit capacity			
	Max. quantity		64			
Compressors	Type		DC inverter			
	Quantity		6			
Fan motors	Type		DC			
	Quantity		6			
	Max. ESP	Pa	20 default; 60 customization option			
Refrigerant	Type		R410A			
	Factory charge	kg	17×2+25		17+22+25	17+22+25
Pipe connections <sup>3</sup>	Liquid pipe	mm			Φ22.2	
	Gas pipe	mm			Φ44.5	
Airflow rate		m <sup>3</sup> /h	58000		66000	66000
Sound pressure level <sup>4</sup>		dB(A)	68			
Net dimensions (WxHxD)		mm	(1340×1635×790)×2+(1730×1830×825)		(1340×1635×790)+(1730×1830×825)×2	
Packed dimensions (WxHxD)		mm	(1405×1805×910)×2+(1800×2000×910)		(1405×1805×910)+(1800×2000×910)×2	
Net weight		kg	348×2+475		348+430+475	
Gross weight		kg	368×2+507		368+453+507	
Ambient temp. operating range	Cooling	°C	-5 to 48			
	Heating	°C	-23 to 24			

## Notes:

- Indoor temperature 27°C DB, 19°C WB; outdoor temperature 35°C DB; equivalent refrigerant piping length 7.5m with zero level difference.
- Indoor temperature 20°C DB; outdoor temperature 7°C DB, 6°C WB; equivalent refrigerant piping length 7.5m with zero level difference.
- Diameters given are those for the pipe connecting the outdoor unit combination to the first indoor branch joint for systems with total equivalent liquid piping lengths of less than 90m. For systems with total equivalent liquid piping lengths of 90m or longer, please refer to the V6 Series Engineering Data Book for connection piping diameters.
- Sound pressure level is measured at a position 1m in front of the unit and 1.3m above the floor in a semi-anechoic chamber.

# Specifications(Super X)



Capacity		HP	82	84	86	88
Model			38VF082H119016-E	38VF084H119016-E	38VF086H119016-E	38VF088H119016-E
Combination type			22HP+28HP+32HP	26HP+26HP+32HP	26HP+28HP+32HP	28HP+28HP+32HP
Power supply		V/Ph/Hz	380-415/3/50			
Cooling <sup>1</sup>	Capacity	kW	230.0	236.0	241.5	247.0
		kBtu/h	784.8	805.2	824.0	842.8
	Power input	kW	73.5	72.8	76.1	79.3
		EER	kW/kW	3.13	3.24	3.17
Heating <sup>2</sup>	Capacity	kW	230.0	236.0	241.5	247.0
		kBtu/h	784.8	805.2	824.0	842.8
	Power input	kW	61.4	60.9	64.0	67.0
		COP	kW/kW	3.75	3.87	3.78
Connectable Indoor Unit	Total capacity	50-130% of outdoor unit capacity				
	Max. quantity	64				
Compressors	Type	DC inverter				
	Quantity	6				
Fan motors	Type	DC				
	Quantity	6				
	Max. ESP	Pa	20 default; 60 customization option			
Refrigerant	Type	R410A				
	Factory charge	kg	17+22+25		22×2+25	
Pipe connections <sup>3</sup>	Liquid pipe	mm	Φ22.2		Φ25.4	
	Gas pipe	mm	Φ44.5		Φ50.8	
Airflow rate		m <sup>3</sup> /h	66000		74000	
Sound pressure level <sup>4</sup>		dB(A)	68			
Net dimensions (WxHxD)		mm	(1340×1635×790)+(1730×1830×825)×2		(1730×1830×825)×3	
Packed dimensions (WxHxD)		mm	(1405×1805×910)+(1800×2000×910)×2		(1800×2000×910)×3	
Net weight		kg	348+430+475		430×2+475	
Gross weight		kg	368+453+507		453×2+507	
Ambient temp. operating range	Cooling	°C	-5 to 48			
	Heating	°C	-23 to 24			



Capacity		HP	90	92	94	96
Model			38VF090H119016-E	38VF092H119016-E	38VF094H119016-E	38VF096H119016-E
Combination type			28HP+30HP+32HP	28HP+32HP+32HP	30HP+32HP+32HP	32HP+32HP+32HP
Power supply		V/Ph/Hz	380-415/3/50			
Cooling <sup>1</sup>	Capacity	kW	253.5	258.5	265.0	270.0
		kBtu/h	864.9	882.0	904.2	921.2
	Power input	kW	82.6	86.2	89.5	93.1
		EER	kW/kW	3.07	3.00	2.96
Heating <sup>2</sup>	Capacity	kW	253.5	258.5	265.0	270.0
		kBtu/h	864.9	882.0	904.2	921.2
	Power input	kW	69.3	72.1	74.4	77.1
		COP	kW/kW	3.66	3.59	3.56
Connectable Indoor Unit	Total capacity	50-130% of outdoor unit capacity				
	Max. quantity	64				
Compressors	Type	DC inverter				
	Quantity	6				
Fan motors	Type	DC				
	Quantity	6				
	Max. ESP	Pa	20 default; 60 customization option			
Refrigerant	Type	R410A				
	Factory charge	kg	22+25×2		25+25×2	
Pipe connections <sup>3</sup>	Liquid pipe	mm	Φ25.4			
	Gas pipe	mm	Φ50.8			
Airflow rate		m <sup>3</sup> /h	73000		72000	
Sound pressure level <sup>4</sup>		dB(A)	68			
Net dimensions (WxHxD)		mm	(1730×1830×825)×3			
Packed dimensions (WxHxD)		mm	(1800×2000×910)×3			
Net weight		kg	430+475×2		475×3	
Gross weight		kg	453+507×2		507×3	
Ambient temp. operating range	Cooling	°C	-5 to 48			
	Heating	°C	-23 to 24			

Notes:

- Indoor temperature 27°C DB, 19°C WB; outdoor temperature 35°C DB; equivalent refrigerant piping length 7.5m with zero level difference.
- Indoor temperature 20°C DB; outdoor temperature 7°C DB, 6°C WB; equivalent refrigerant piping length 7.5m with zero level difference.
- Diameters given are those for the pipe connecting the outdoor unit combination to the first indoor branch joint for systems with total equivalent liquid piping lengths of less than 90m. For systems with total equivalent liquid piping lengths of 90m or longer, please refer to the V6 Series Engineering Data Book for connection piping diameters.
- Sound pressure level is measured at a position 1m in front of the unit and 1.3m above the floor in a semi-anechoic chamber.

**2<sup>nd</sup> Generation VRF**

**DC INDOOR UNITS**





# Wide Application Range

## Wide Range of Indoor Units

With 11 types and more than 100 models, CarrierVRF indoor units meet varied customer requirements in a wide range of locations including shopping malls, hospitals, office buildings, hotels and airports.



## Multiple Appearance Options

For Wall Mounted Units, three interchangeable panels add extra flexibility to a universal body design.



M3 panel



M9 panel



M10 panel

For Four-way Cassette and Compact Four-way Cassette Units, interchangeable 360° airflow and four-way airflow panels are available.



360° airflow



Four-way airflow

For Floor Standing Units, the F3B (concealed) unit is designed to be concealed in walls while the F4 (front air intake) and F5 (underside air intake) offer a choice of air intake options.



F3B (concealed)



F4 (front air intake)



F5 (underside air intake)



# Comfort and Efficiency

## High Efficiency DC Fan Motor

The power consumption of DC fan motor can be reduced greatly in comparison to corresponding AC type.



## Quiet Operation

The low sound operation DC fan motor and optimized fan blades guarantees the air discharge smoothly and provides a quiet living environment.



## Constant Level of Indoor Air Temperature

Plate Heat Exchanger as a secondary intercooler to gain up to 18°C subcooling and improves 10% energy efficiency.

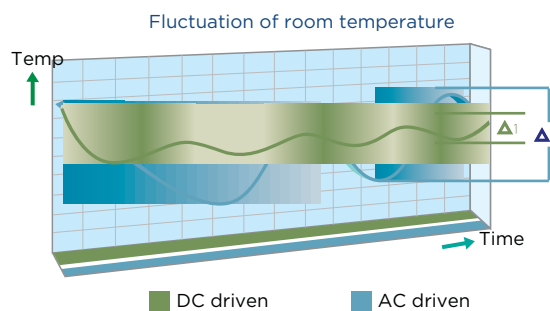

## 5-step Swing Louver

The air is comfortably spread upwards and downwards thanks to the 5-step swing louver that can be programmed via the controller.

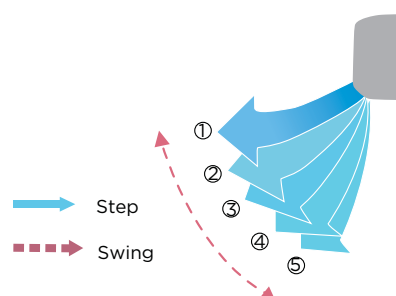

# Comfort and Efficiency

## Static Pressure 20 Steps Control (Duct Unit)

Depending on the installation environment, medium static pressure duct is controlled the static pressure up to 10 steps and high static pressure duct is controlled the static pressure up to 20 steps via wired remote controller, for providing comfortable environment suitable for any environment.

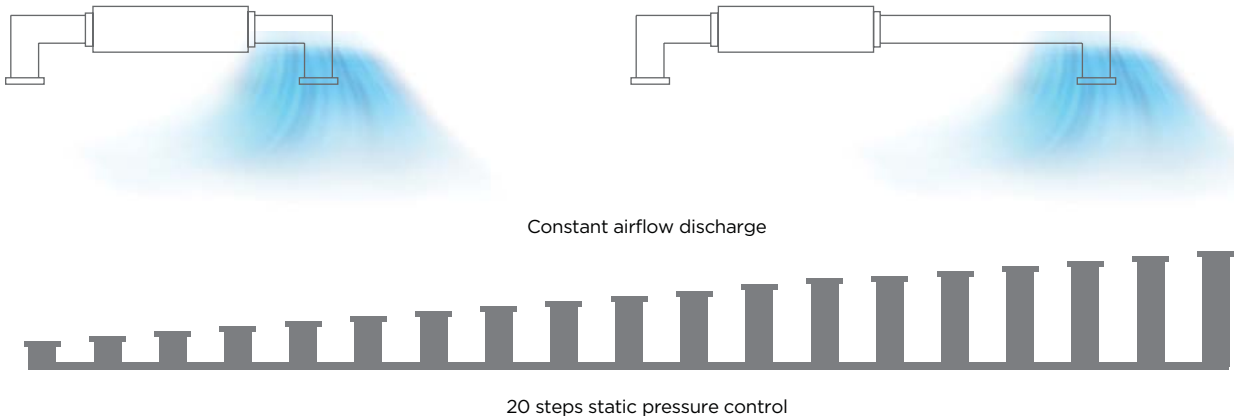

## 7-Speed Fan Control

7 indoor fan speeds provide control flexibility to meet the needs of different indoor conditions.

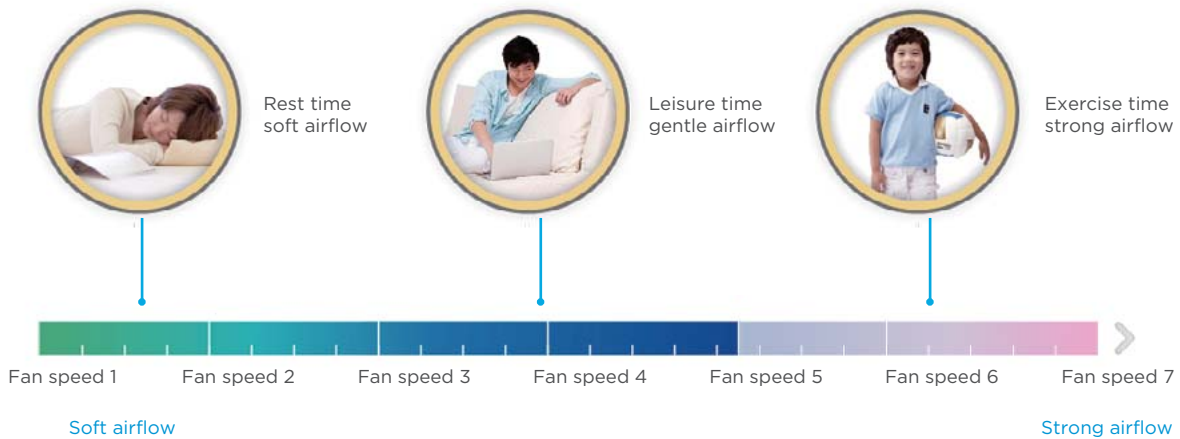

## Fresh Air Intake

On selected models, a reserved outside air intake port allows outdoor air to be introduced directly into the unit, negating the need for a separate ventilation system.



# Convenience

## High-lift Drain Pump

A drain pump with a 750mm or 500mm pump head is fitted as standard or optional, simplifying installation of the drain piping.

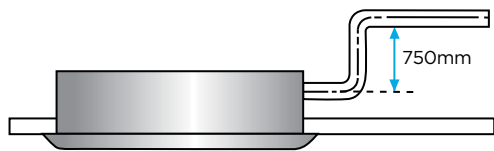

## Flexible Installation

For Medium Static Pressure Duct Units, to provide the flexibility to adapt to differing installation situations, the air inlet may be positioned either on the underside or the rear of the unit.

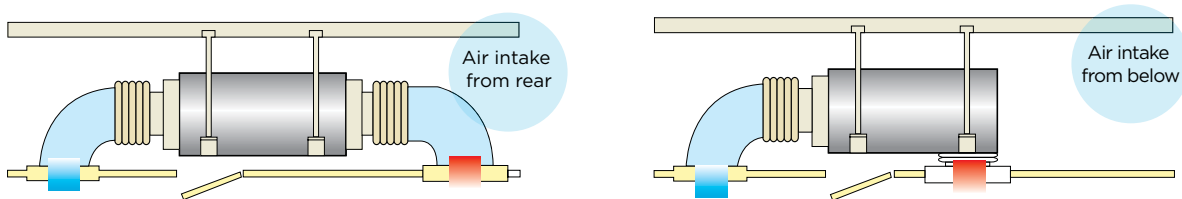

For Wall Mounted Units, the refrigerant outlet direction can be left, right or rear as the installation situation requires. A new fixing plate design speeds installation and provides extra stability.

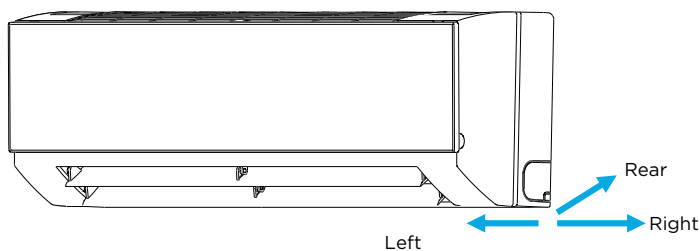

Ceiling / Floor Units can be installed either on the ceiling or the floor, providing flexibility to accommodate a wide range of room designs.

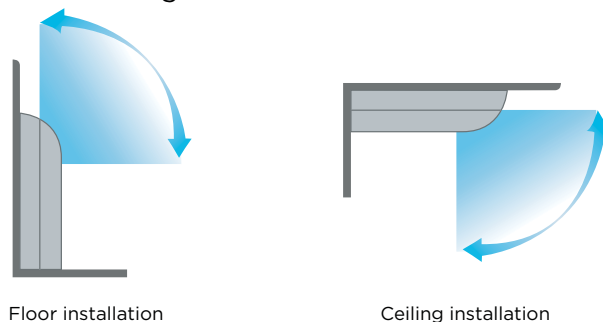

# One-way Cassette

- Fresh air intake
- One-way air discharge, ideal for corner locations
- Drain pump with 750mm pump head fitted as standard



Optional wireless remote controller



WL-12D-CM WL-12B-CM

Optional wired controller



WR-86KD-CM WR-120G-CM

Model			40VZ006H11500016	40VZ007H11500016	40VZ009H11500016	40VZ012H11500016
Power supply			1-phase, 220-240V, 50Hz			
Cooling <sup>1</sup>	Capacity	kW	1.8	2.2	2.8	3.6
		kBtu/h	6.1	7.5	9.6	12.3
	Power input	W	25	25	30	30
Heating <sup>2</sup>	Capacity	kW	2.2	2.6	3.2	4.0
		kBtu/h	7.5	8.9	10.9	13.6
	Power input	W	25	25	30	30
Air flow rate <sup>3</sup>		m <sup>3</sup> /h	523/482/448/404/360/312/275		573/531/492/456/420/364/315	
Sound pressure level <sup>4</sup>		dB(A)	37/36/35/34/32/31/30		39/38/37/36/35/35/34	
Main body	Net dimensions <sup>5</sup> (WxHxD)	mm	1054×153×425			
	Packed dimensions (WxHxD)	mm	1155×245×490			
	Net/Gross weight	kg	11.8/15.3		12.3/15.8	
Panel	Net dimensions (WxHxD)	mm	1180×25×465			
	Packed dimensions (WxHxD)	mm	1232×107×517			
	Net/Gross weight	kg	3.5/5.2			
Pipe connections	Liquid/Gas pipe	mm	Φ6.35/Φ12.7			
	Drain pipe	mm	OD Φ32			

Model			40VZ016H11500016	40VZ020H11500016	40VZ024H11500016	
Power supply			1-phase, 220-240V, 50Hz			
Cooling <sup>1</sup>	Capacity	kW	4.5	5.6	7.1	
		kBtu/h	15.4	19.1	24.2	
	Power input	W	40	48	60	
Heating <sup>2</sup>	Capacity	kW	5.0	6.3	8.0	
		kBtu/h	17.1	21.5	27.3	
	Power input	W	40	48	60	
Air flow rate <sup>3</sup>		m <sup>3</sup> /h	693/662/638/600/556/510/476	792/763/728/688/643/589/549	933/873/815/749/689/637/592	
Sound pressure level <sup>4</sup>		dB(A)	41/40/39/38/37/36/35	42/41/40/39/38/37/36	44/43/42/41/39/38/37	
Main body	Net dimensions <sup>5</sup> (WxHxD)	mm	1275×189×450			
	Packed dimensions (WxHxD)	mm	1370×295×505			
	Net/Gross weight	kg	16.1/20.4	16.4/20.7	17.6/22.4	
Panel	Net dimensions (WxHxD)	mm	1350×25×505			
	Packed dimensions (WxHxD)	mm	1410×95×560			
	Net/Gross weight	kg	4/5.4			
Pipe connections	Liquid/Gas pipe	mm	Φ6.35/Φ12.7	Φ9.53/Φ15.9		
	Drain pipe	mm	OD Φ32			

Notes:

1. Indoor temperature 27°C DB, 19°C WB; outdoor temperature 35°C DB; equivalent refrigerant piping length 7.5m with zero level difference.
2. Indoor temperature 20°C DB; outdoor temperature 7°C DB, 6°C WB; equivalent refrigerant piping length 7.5m with zero level difference.
3. Each model's 7 airflow rate options are listed in order, from highest to lowest.
4. Each model's 7 sound pressure levels are listed in order from highest to lowest and correspond to the model's 7 airflow rate options (see Note 3). Sound pressure level is measured 1.4m below the unit in a semi-anechoic chamber.
5. Unit body dimensions given are the largest external dimensions of the unit, including hanger attachments.

# Two-way Cassette

- Two-way air discharge, perfect for limited ceiling space applications
- Drain pump with 750mm pump head fitted as standard



Optional wireless remote controller



WL-12D-CM WL-12B-CM

Optional wired controller

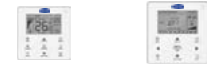

WR-86KD-CM WR-120G-CM

Model			40VT007H11500016	40VT009H11500016	40VT012H11500016
Power supply			1-phase, 220-240V, 50Hz		
Cooling <sup>1</sup>	Capacity	kW	2.2	2.8	3.6
		kBtu/h	7.5	9.6	12.3
	Power input	W	35	40	40
Heating <sup>2</sup>	Capacity	kW	2.6	3.2	4.0
		kBtu/h	8.9	10.9	13.6
	Power input	W	35	40	40
Air flow rate <sup>3</sup>		m <sup>3</sup> /h	654/612/571/530/488/449/410		725/679/641/591/554/509/458
Sound pressure level <sup>4</sup>		dB(A)	33/31/30/29/27/25/24		35/33/32/30/29/27/25
Main body	Net dimensions <sup>5</sup> (W×H×D)	mm	1172×299×591		
	Packed dimensions (W×H×D)	mm	1355×400×675		
	Net/Gross weight	kg	33.5/42.0		
Panel	Net dimensions (W×H×D)	mm	1430×53×680		
	Packed dimensions (W×H×D)	mm	1525×130×765		
	Net/Gross weight	kg	10.5/15		
Pipe connections	Liquid/Gas pipe	mm	Φ6.35/Φ12.7		
	Drain pipe	mm	OD Φ32		

Model			40VT016H11500016	40VT020H11500016	40VT024H11500016
Power supply			1-phase, 220-240V, 50Hz		
Cooling <sup>1</sup>	Capacity	kW	4.5	5.6	7.1
		kBtu/h	15.4	19.1	24.2
	Power input	W	50	69	98
Heating <sup>2</sup>	Capacity	kW	5.0	6.3	8.0
		kBtu/h	17.1	21.5	27.3
	Power input	W	50	69	98
Air flow rate <sup>3</sup>		m <sup>3</sup> /h	850/792/731/670/631/592/550	980/925/855/800/755/702/670	1200/1115/1068/1000/921/808/770
Sound pressure level <sup>4</sup>		dB(A)	37/36/35/34/32/31/30	39/37/36/35/33/31/30	44/42/41/40/38/36/34
Main body	Net dimensions <sup>5</sup> (W×H×D)	mm	1172×299×591		
	Packed dimensions (W×H×D)	mm	1355×400×675		
	Net/Gross weight	kg	35/43.5		
Panel	Net dimensions (W×H×D)	mm	1430×53×680		
	Packed dimensions (W×H×D)	mm	1525×130×765		
	Net/Gross weight	kg	10.5/15		
Pipe connections	Liquid/Gas pipe	mm	Φ6.35/Φ12.7	Φ9.53/Φ15.9	
	Drain pipe	mm	OD Φ32		

**Notes:**

1. Indoor temperature 27°C DB, 19°C WB; outdoor temperature 35°C DB; equivalent refrigerant piping length 7.5m with zero level difference.
2. Indoor temperature 20°C DB; outdoor temperature 7°C DB, 6°C WB; equivalent refrigerant piping length 7.5m with zero level difference.
3. Each model's 7 airflow rate options are listed in order, from highest to lowest.
4. Each model's 7 sound pressure levels are listed in order from highest to lowest and correspond to the model's 7 airflow rate options (see Note 3).  
Sound pressure level is measured 1.4m below the unit in a semi-anechoic chamber.
5. Unit body dimensions given are the largest external dimensions of the unit, including hanger attachments.

# Compact Four-way Cassette

Fresh air intake

360° airflow allows for even, wide-range cooling and heating

Drain pump with 500mm pump head fitted as standard



Optional wireless remote controller



WL-12D-CM

WL-12B-CM

Optional wired controller



WR-86KD-CM

WR-120G-CM

Model			40VX007H11500016	40VX009H11500016	40VX012H11500016	40VX016H11500016
Power supply			1-phase, 220-240V, 50Hz			
Cooling <sup>1</sup>	Capacity	kW	2.2	2.8	3.6	4.5
		kBtu/h	7.5	9.6	12.3	15.4
	Power input	W	35	35	40	50
Heating <sup>2</sup>	Capacity	kW	2.4	3.2	4.0	5.0
		kBtu/h	8.2	10.9	13.6	17.1
	Power input	W	35	35	40	50
Air flow rate <sup>3</sup>		m <sup>3</sup> /h	576/552/524/503/462/441/405		604/573/541/516/478/434/400	
Sound pressure level <sup>4</sup>		dB(A)	35/34/33/29/26/23/22		41/38/35/32/30/29/28	
Main body	Net dimensions <sup>5</sup> (WxHxD)	mm	630×260×570			
	Packed dimensions (WxHxD)	mm	700×330×660			
	Net/Gross weight	kg	18/23.5		19.2/24.7	
Panel	Net dimensions (W×H×D)	mm	647×50×647			
	Packed dimensions (W×H×D)	mm	715×123×715			
	Net/Gross weight	kg	2.5/4.5			
Pipe connections	Liquid/Gas pipe	mm	Φ6.35/Φ12.7			
	Drain pipe	mm	OD Φ32			

**Notes:**

- Indoor temperature 27°C DB, 19°C WB; outdoor temperature 35°C DB; equivalent refrigerant piping length 7.5m with zero level difference.
- Indoor temperature 20°C DB; outdoor temperature 7°C DB, 6°C WB; equivalent refrigerant piping length 7.5m with zero level difference.
- Each model's 7 airflow rate options are listed in order, from highest to lowest.
- Each model's 7 sound pressure levels are listed in order from highest to lowest and correspond to the model's 7 airflow rate options (see Note 3).  
Sound pressure level is measured 1.4m below the unit in a semi-anechoic chamber.
- Unit body dimensions given are the largest external dimensions of the unit, including hanger attachments.

# Four-way Cassette

- Fresh air intake
- Four-way airflow, allows wide-angle, equal distribution of cooling and heating
- Drain pump with 750mm pump head fitted as standard
- Brand-new, elegant panel with four independently controlled louvers



Optional wireless remote controller

Optional wired controller



WL-12D-CM

WL-12B-CM

WR-86KD-CM

WR-120G-CM

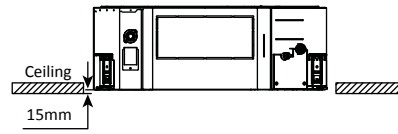
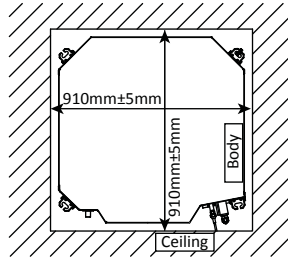

New panel appearance (optional)

New panel installation dimensions

Model		40VK009H11500016	40VK012H11500016	40VK016H11500016	40VK020H11500016	40VK024H11500016	
Power supply		1 phase, 220-240V, 50Hz					
Cooling <sup>1</sup>	Capacity	kW	2.8	3.6	4.5	5.6	7.1
		kBtu/h	9.6	12.3	15.4	19.1	24.2
	Power input	W	25	25	31	31	46
Heating <sup>2</sup>	Capacity	kW	3.2	4.0	5.0	6.3	8.0
		kBtu/h	10.9	13.6	17.1	21.5	27.3
	Power input	W	25	25	31	31	46
Air flow rate <sup>3</sup>	m <sup>3</sup> /h	982/935/877/832/788/732/677			1029/957/899/857/801/756/704		1200/1132/1065/996/920/866/748
Sound pressure level <sup>4</sup>	dB(A)	42/40/38/37/35/34/32			43/41/39/38/36/35/34		45/43/41/39/37/35/34
Main body	Net dimensions <sup>5</sup> (WxHxD)	mm	904×230×840				
	Packed dimensions (WxHxD)	mm	955×260×955				
	Net/Gross weight	kg	21.3/25.8		23.2/27.6		
Panel	Net dimensions (WxHxD)	mm	950×54.5×950				
	Packed dimensions (WxHxD)	mm	1035×90×1035				
	Net/Gross weight	kg	5/8				
Pipe connections	Liquid/Gas pipe	mm	Φ6.35/Φ12.7			Φ9.53/Φ15.9	
	Drain pipe	mm	OD Φ32				

Model		40VK028H11500016	40VK030H11500016	40VK034H11500016	40VK036H11500016	40VK048H11500016	
Power supply		1 phase, 220-240V, 50Hz					
Cooling <sup>1</sup>	Capacity	kW	8.0	9.0	10.0	11.2	14.0
		kBtu/h	27.3	30.7	34.1	38.2	47.8
	Power input	W	48	75	75	75	94
Heating <sup>2</sup>	Capacity	kW	9.0	10.0	11.0	12.5	16.0
		kBtu/h	30.7	34.1	37.5	42.7	54.6
	Power input	W	48	75	75	75	94
Air flow rate <sup>3</sup>	m <sup>3</sup> /h	1264/1195/1117/1055/975/893/811		1596/1477/1365/1239/1154/1087/1034		1727/1622/1517/1426/1351/1289/1224	
Sound pressure level <sup>4</sup>	dB(A)	46/44/42/40/38/36/35		47/45/43/41/39/37/36		50/48/46/45/38/36/35	
Main body	Net dimensions <sup>5</sup> (WxHxD)	mm	904×230×840		904×300×840		
	Packed dimensions (WxHxD)	mm	955×260×955		955×330×955		
	Net/Gross weight	kg	23.2/27.6		28.4/33.8		30.7/35.8
Panel	Net dimensions (WxHxD)	mm	950×54.5×950				
	Packed dimensions (WxHxD)	mm	1035×90×1035				
	Net/Gross weight	kg	5/8				
Pipe connections	Liquid/Gas pipe	mm	Φ9.53/Φ15.9				
	Drain pipe	mm	OD Φ32				

Notes:

1. Indoor temperature 27°C DB, 19°C WB; outdoor temperature 35°C DB; equivalent refrigerant piping length 7.5m with zero level difference.
2. Indoor temperature 20°C DB; outdoor temperature 7°C DB, 6°C WB; equivalent refrigerant piping length 7.5m with zero level difference.
3. Each model's 7 airflow rate options are listed in order, from highest to lowest.
4. Each model's 7 sound pressure levels are listed in order from highest to lowest and correspond to the model's 7 airflow rate options (see Note 3). Sound pressure level is measured 1.4m below the unit in a semi-anechoic chamber.
5. Unit body dimensions given are the largest external dimensions of the unit, including hanger attachments.

# Medium Static Pressure Duct

Fresh air intake

6-step static pressure control on 2.2kW to 7.1kW models and 10-step static pressure control on 8kW to 14kW units (requires latest generation wired controllers)

Drain pump with 750mm pump head fitted as standard  
Flexible installation for the air inlet may be positioned either on the underside or the rear of the unit



Optional wireless remote controller

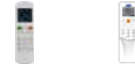

WL-12D-CM WL-12B-CM

Optional wired controller



WR-86KD-CM WR-120G-CM

Model		42VD007H115003016		42VD009H115003016		42VD012H115003016			
Power supply		1 phase, 220-240V, 50Hz							
Cooling <sup>1</sup>	Capacity	kW	2.2	2.8	3.6	kBtu/h	7.5	9.6	12.3
	Power input	W	40	40	45				
Heating <sup>2</sup>	Capacity	kW	2.6	3.2	4.0	kBtu/h	8.2	10.9	13.6
	Power input	W	40	40	45				
Air flow rate <sup>3</sup>	m <sup>3</sup> /h	520/480/440/400/360/330/300					580/540/500/460/430/400/370		
External static pressure	Pa	10 (0~50)							
Sound pressure level <sup>4</sup>	dB(A)	35/35/34/34/33/32/31					37/37/36/36/35/34/33		
Unit	Net dimensions <sup>5</sup> (WxHxD)	mm	780×210×500						
	Packed dimensions (WxHxD)	mm	870×285×525						
	Net/Gross weight	kg	18/21						
Pipe connections	Liquid/Gas pipe	mm	Φ6.35/ Φ12.7						
	Drain pipe	mm	OD Φ25						

Model		42VD016H115003016		42VD020H115003016		42VD024H115003016			
Power supply		1 phase, 220-240V, 50Hz							
Cooling <sup>1</sup>	Capacity	kW	4.5	5.6	7.1	kBtu/h	15.4	19.1	24.2
	Power input	W	92	92	98				
Heating <sup>2</sup>	Capacity	kW	5.0	6.3	8.0	kBtu/h	17.1	21.5	27.3
	Power input	W	92	92	98				
Air flow rate <sup>3</sup>	m <sup>3</sup> /h	800/740/680/620/540/480/400		830/760/720/680/640/600/560		1000/960/900/840/780/720/680			
External static pressure	Pa	10 (0~50)							
Sound pressure level <sup>4</sup>	dB(A)	38/37/37/36/35/34/33			38/38/37/36/35/34/33		40/39/38/37/36/35/34		
Unit	Net dimensions <sup>5</sup> (WxHxD)	mm	1000×210×500			1220×210×500			
	Packed dimensions (WxHxD)	mm	1115×285×525			1335×285×525			
	Net/Gross weight	kg	21.5/25			27.5/31.5			
Pipe connections	Liquid/Gas pipe	mm	Φ6.35/ Φ12.7		Φ9.53/Φ15.9				
	Drain pipe	mm	OD Φ25						

Model		42VD028H115003016		42VD030H115003016		42VD036H115003016		42VD048H115003016			
Power supply		1 phase, 220-240V, 50Hz									
Cooling <sup>1</sup>	Capacity	kW	8.0	9.0	11.2	14.0	kBtu/h	27.3	30.7	38.2	47.8
	Power input	W	110	120	200	250					
Heating <sup>2</sup>	Capacity	kW	9.0	10.0	12.5	15.5	kBtu/h	30.7	34.1	42.7	52.9
	Power input	W	110	120	200	250					
Air flow rate <sup>3</sup>	m <sup>3</sup> /h	1260/1180/1100/1020/940/860/780				1500/1430/1360/1290/1210/1140/1080		1960/1860/1760/1660/1560/1460/1360			
External static pressure	Pa	20 (10~100)									
Sound pressure level <sup>4</sup>	dB(A)	44/43/42/41/39/38/37				47/46/44/43/41/39/37		47/46/44/43/41/39/38			
Unit	Net dimensions <sup>5</sup> (WxHxD)	mm	1230×270×775				1290×300×865				
	Packed dimensions (WxHxD)	mm	1355×350×795				1400×375×925				
	Net/Gross weight	kg	36.5/44.5	37/45			46.5/55.5				
Pipe connections	Liquid/Gas pipe	mm	Φ9.53/Φ15.9								
	Drain pipe	mm	OD Φ25								

Notes:

- Indoor temperature 27°C DB, 19°C WB; outdoor temperature 35°C DB; equivalent refrigerant piping length 7.5m with zero level difference.
  - Indoor temperature 20°C DB; outdoor temperature 7°C DB, 6°C WB; equivalent refrigerant piping length 7.5m with zero level difference.
  - Each model's 7 airflow rate options are listed in order, from highest to lowest.
  - Each model's 7 sound pressure levels are listed in order from highest to lowest and correspond to the model's 7 airflow rate options (see Note 3).  
Sound pressure level is measured 1.4m below the unit in a semi-anechoic chamber.
  - Unit body dimensions given are the largest external dimensions of the unit, including hanger attachments.
- All specifications are measured at standard external static pressure.



# High Static Pressure Duct

- External static pressure up to 400Pa facilitates extensive duct and grille network
- 20-step static pressure control on all models (requires latest generation wired controllers)
- A double-skin drainage pan provides double protection for ceilings (models 71 to 160).
- Drain pump with a 750mm pump head available as a customization option



Optional wireless remote controller



WL-12D-CM WL-12B-CM

Optional wired controller



WR-86KD-CM WR-120G-CM

Model		42VD024H115011016*		42VD028H115011016*		42VD030H115011016		
Power supply		1 phase, 220-240V, 50Hz						
Cooling <sup>1</sup>	Capacity	kW	7.1	8.0	9.0			
		kBtu/h	24.2	27.3	30.7			
Power input	W		180	180	220			
Heating <sup>2</sup>	Capacity	kW	8.0	9.0	10.0			
		kBtu/h	27.3	30.7	34.1			
Power input	W		180	180	220			
Air flow rate <sup>3</sup>	m <sup>3</sup> /h		1360/1333/1296/1264/1234/1197/1159	1360/1333/1296/1264/1234/1197/1159	1428/1378/1328/1285/1237/1195/1151			
External static pressure	Pa	100 (30~ 200)						
Sound pressure level <sup>4</sup>	dB(A)	46/46/45/45/44/43/42		46/46/45/45/44/43/42		50/49/48/48/47/46/45		
Unit	Net dimensions <sup>5</sup> (WxHxD)	mm	952×420×690					
	Packed dimensions (WxHxD)	mm	1090×440×768					
	Net/Gross weight	kg	41/47				51/57	
Pipe connections	Liquid/Gas pipe	mm	Φ9.53/Φ15.9					
	Drain pipe	mm	OD Φ25					

Model		42VD036H115011016		42VD048H115011016		42VD054H115011016		
Power supply		1 phase, 220-240V, 50Hz						
Cooling <sup>1</sup>	Capacity	kW	11.2	14.0	16.0			
		kBtu/h	38.2	47.8	54.6			
Power input	W		380	420	700			
Heating <sup>2</sup>	Capacity	kW	12.5	16.0	17.0			
		kBtu/h	42.7	54.6	58.0			
Power input	W		380	420	700			
Air flow rate <sup>3</sup>	m <sup>3</sup> /h		1886/1775/1695/1614/1528/1429/1354	2258/2127/2033/1927/1818/1707/1601	2608/2501/2354/2239/2099/2013/1879			
External static pressure	Pa	100 (30~ 200)						
Sound pressure level <sup>4</sup>	dB(A)	50/50/49/48/47/46/45		53/52/51/51/50/49/48		54/54/53/52/51/50/50		
Unit	Net dimensions <sup>5</sup> (WxHxD)	mm	952×420×690				1300×420×690	
	Packed dimensions (WxHxD)	mm	1090×440×768				1436×450×768	
	Net/Gross weight	kg	51/57				63/70	
Pipe connections	Liquid/Gas pipe	mm	Φ9.53/Φ19.1					
	Drain pipe	mm	OD Φ25					

Model		42VD070H115011016		42VD085H115011016		42VD096H115011016		
Power supply		1 phase, 220-240V, 50Hz						
Cooling <sup>1</sup>	Capacity	kW	20.0	25.0	28.0			
		kBtu/h	68.2	85.3	95.5			
Power input	W		990	1200	1200			
Heating <sup>2</sup>	Capacity	kW	22.5	26.0	31.5			
		kBtu/h	76.8	88.7	107.5			
Power input	W		990	1200	1200			
Air flow rate <sup>3</sup>	m <sup>3</sup> /h	4358/4237/4144/4043/3941/3837/3745						
External static pressure	Pa	170 (20~250)						
Sound pressure level <sup>4</sup>	dB(A)	57/56/55/54/53/52/50						
Unit	Net dimensions <sup>5</sup> (WxHxD)	mm	1440×505×925					
	Packed dimensions (WxHxD)	mm	1509×550×990					
	Net/Gross weight	kg	130/142					
Pipe connections	Liquid/Gas pipe	mm	Φ12.7/Φ22.2					
	Drain pipe	mm	OD Φ32					

## Notes:

1. Indoor temperature 27°C DB, 19°C WB; outdoor temperature 35°C DB; equivalent refrigerant piping length 7.5m with zero level difference.
2. Indoor temperature 20°C DB; outdoor temperature 7°C DB, 6°C WB; equivalent refrigerant piping length 7.5m with zero level difference.
3. Each model's 7 airflow rate options are listed in order, from highest to lowest.
4. Each model's 7 sound pressure levels are listed in order from highest to lowest and correspond to the model's 7 airflow rate options (see Note 3).  
Sound pressure level is measured 1.4m below the unit in a semi-anechoic chamber.
5. Unit body dimensions given are the largest external dimensions of the unit, including hanger attachments.

All specifications are measured at standard external static pressure.

\* Available Q3 2019

# Fresh Air Processing Unit

100% fresh air processing unit, both fresh air filtration and heating/cooling can be achieved in a single system

External static pressure up to 400Pa facilitates extensive duct and grille network

20-step static pressure control on all models (requires latest generation wired controllers)

Drain pump with a 750mm pump head available as a customization option



Optional wireless remote controller



WL-12D-CM

WL-12B-CM

Optional wired controller



WR-86KD-CM

WR-120G-CM

Model			42VD042H115211016*	42VD048H115211016*
Power supply			1 phase, 220-240V, 50Hz	
Cooling <sup>1</sup>	Capacity	kW	12.5	14.0
		kBtu/h	42.6	47.8
	Power input	W	370	370
Heating <sup>2</sup>	Capacity	kW	10.5	12.0
		kBtu/h	36.0	41.0
	Power input	W	370	370
Air flow rate <sup>3</sup>		m <sup>3</sup> /h	2440/2279/2117/1956/1794/1632/1470	
External static pressure		Pa	180 (30~200)	
Sound pressure level <sup>4</sup>		dB(A)	52/51/51/50/50/49/48	
Unit	Net dimensions <sup>5</sup> (WxHxD)		1300x420x690	
	Packed dimensions (WxHxD)		1436x450x768	
	Net/Gross weight		63/70	
Pipe connections	Liquid/Gas pipe		Φ9.53/Φ19.1	
	Drain pipe		OD Φ25	

Model			42VD070H115211016	42VD085H115211016	42VD096H115211016
Power supply			1 phase, 220-240V, 50Hz		
Cooling <sup>1</sup>	Capacity	kW	20.0	25.0	28.0
		kBtu/h	68.2	85.3	95.5
	Power input	W	615	670	670
Heating <sup>2</sup>	Capacity	kW	18.0	20.0	22.0
		kBtu/h	61.4	68.2	75.0
	Power input	W	615	670	670
Air flow rate <sup>3</sup>		m <sup>3</sup> /h	3860/3699/3537/3376/3214/3053/2890		
External static pressure		Pa	200 (30~250)		
Sound pressure level <sup>4</sup>		dB(A)	53/53/52/52/51/50/50		
Unit	Net dimensions <sup>5</sup> (WxHxD)		1450x505x925		
	Packed dimensions (WxHxD)		1509x550x990		
	Net/Gross weight		130/142		
Pipe connections	Liquid/Gas pipe		Φ12.7/Φ22.2		
	Drain pipe		OD Φ32		

**Notes:**

- Indoor temperature 27°C DB, 19°C WB; outdoor temperature 35°C DB; equivalent refrigerant piping length 7.5m with zero level difference.
  - Indoor temperature 20°C DB; outdoor temperature 7°C DB, 6°C WB; equivalent refrigerant piping length 7.5m with zero level difference.
  - Each model's 7 airflow rate options are listed in order, from highest to lowest.
  - Each model's 7 sound pressure levels are listed in order from highest to lowest and correspond to the model's 7 airflow rate options (see Note 3).  
Sound pressure level is measured 1.4m below the unit in a semi-anechoic chamber.
  - Unit body dimensions given are the largest external dimensions of the unit, including hanger attachments.
- All specifications are measured at standard external static pressure.

\* Available Q3 2019

# Wall Mounted Unit

- Three interchangeable panels allow units to blend easily with any interior decoration, perfect for rooms with no false ceilings or free floor space
- Refrigerant outlet direction can be left, right or rear as the installation situation requires



Optional wireless remote controller

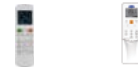

WL-12D-CM

WL-12B-CM

Optional wired controller



WR-86KD-CM

WR-120G-CM

Model		42VH007H115000106		42VH009H115000106	
Power supply		1 phase, 220-240V, 50Hz			
Cooling <sup>1</sup>	Capacity	kW	2.2	2.8	
		kBtu/h	7.5	9.6	
	Power input	W	28	28	
Heating <sup>2</sup>	Capacity	kW	2.4	3.2	
		kBtu/h	8.2	10.9	
	Power input	W	28	28	
Air flow rate <sup>3</sup>		m <sup>3</sup> /h	422/411/402/393/380/368/356		417/402/386/370/353/338/316
Sound pressure level <sup>4</sup>		dB(A)	31/30/30/30/29/29/29		31/30/30/30/29/29/29
Unit	Net dimensions <sup>5</sup> (WxHxD)	mm	835×280×203		
	Packed dimensions (WxHxD)	mm	935×385×320		
	Net/Gross weight	kg	8.4/12.1	9.5/13.1	
Pipe connections	Liquid/Gas pipe	mm	Φ6.35/Φ12.7		
	Drain pipe	mm	OD Φ16		

Model		42VH012H115000106		42VH016H115000106		42VH020H115000106	
Power supply		1 phase, 220-240V, 50Hz					
Cooling <sup>1</sup>	Capacity	kW	3.6	4.5	5.6		
		kBtu/h	12.3	15.4	19.1		
	Power input	W	30	40	45		
Heating <sup>2</sup>	Capacity	kW	4.0	5.0	6.3		
		kBtu/h	13.6	17.1	21.5		
	Power input	W	30	40	45		
Air flow rate <sup>3</sup>		m <sup>3</sup> /h	656/628/591/573/544/515/488	594/563/535/507/478/450/424	747/713/685/648/613/578/547		
Sound pressure level <sup>4</sup>		dB(A)	33/32/32/31/31/30/30	35/34/33/33/32/31/31	38/37/36/36/35/34/34		
Unit	Net dimensions <sup>5</sup> (WxHxD)	mm	990×315×223				
	Packed dimensions (WxHxD)	mm	1085×420×335				
	Net/Gross weight	kg	11.4/15.5	12.8/16.9			
Pipe connections	Liquid/Gas pipe	mm	Φ6.35/Φ12.7			Φ9.53/Φ15.9	
	Drain pipe	mm	OD Φ16				

Model		42VH024H115000106		42VH028H115000106		42VH030H115000106	
Power supply		1 phase, 220-240V, 50Hz					
Cooling <sup>1</sup>	Capacity	kW	7.1	8.0	9.0		
		kBtu/h	24.2	27.3	30.7		
	Power input	W	55	55	82		
Heating <sup>2</sup>	Capacity	kW	8.0	9.0	10.0		
		kBtu/h	27.3	30.7	34.1		
	Power input	W	55	55	82		
Air flow rate <sup>3</sup>		m <sup>3</sup> /h	1195/1130/1065/1005/940/875/809	1195/1130/1065/1005/940/875/809	1421/1300/1125/1067/1005/934/867		
Sound pressure level <sup>4</sup>		dB(A)	44/43/42/39/38/37/36	44/43/42/39/38/37/36	48/46/45/43/41/40/38		
Unit	Net dimensions <sup>5</sup> (WxHxD)	mm	1194×343×262				
	Packed dimensions (WxHxD)	mm	1290×375×460				
	Net/Gross weight	kg	17.0/22.4				
Pipe connections	Liquid/Gas pipe	mm	Φ9.53/Φ15.9			Φ9.53/Φ15.9	
	Drain pipe	mm	OD Φ16				

Notes:

1. Indoor temperature 27°C DB, 19°C WB; outdoor temperature 35°C DB; equivalent refrigerant piping length 7.5m with zero level difference.
2. Indoor temperature 20°C DB; outdoor temperature 7°C DB, 6°C WB; equivalent refrigerant piping length 7.5m with zero level difference.
3. Each model's 7 airflow rate options are listed in order, from highest to lowest.
4. Each model's 7 sound pressure levels are listed in order from highest to lowest and correspond to the model's 7 airflow rate options (see Note 3).  
Sound pressure level is measured 1m in front and 1m below the unit in a semi-anechoic chamber.
5. Unit body dimensions given are the largest external dimensions of the unit, including hanger attachments.

# Ceiling / Floor

Can be installed either on the ceiling or floor



Optional wireless remote controller



Optional wired controller



WL-12D-CM WL-12B-CM WR-86KD-CM WR-120G-CM

Model			42VF012H115000016	42VF016H115000016	42VF020H115000016	42VF024H115000016
Power supply			1 phase, 220-240V, 50Hz			
Cooling <sup>1</sup>	Capacity	kW	3.6	4.5	5.6	7.1
		kBtu/h	12.3	15.4	19.1	24.2
	Power input	W	49	115	115	115
Heating <sup>2</sup>	Capacity	kW	4.0	5.0	6.3	8.0
		kBtu/h	13.6	17.1	21.5	27.3
	Power input	W	49	115	115	115
Air flow rate <sup>3</sup>		m <sup>3</sup> /h	550/525/500/480/460/440/420		930/895/860/830/792/755/720	
Sound pressure level <sup>4</sup>		dB(A)	40/39/38/38/37/36/36		43/42/41/41/39/38/38	
	Net dimensions <sup>5</sup> (WxHxD)	mm	990×660×203			
	Packed dimensions (WxHxD)	mm	1089×744×296			
	Net/Gross weight	kg	26/32		28/34	
Pipe connections	Liquid/Gas pipe	mm	Φ6.35/Φ12.7		Φ9.53/Φ15.9	
	Drain pipe	mm	OD Φ16			

Model			42VF028H115000016	42VF030H115000016	42VF036H115000016	42VF048H115000016
Power supply			1 phase, 220-240V, 50Hz			
Cooling <sup>1</sup>	Capacity	kW	8.0	9.0	11.2	14.0
		kBtu/h	27.2	30.7	38.2	47.8
	Power input	W	130	130	180	180
Heating <sup>2</sup>	Capacity	kW	9.0	10.0	12.5	15.0
		kBtu/h	30.7	34.1	42.7	51.2
	Power input	W	130	130	180	180
Air flow rate <sup>3</sup>		m <sup>3</sup> /h	1280/1245/1210/1170/1130/1085/1050		1890/1830/1765/1700/1660/1620/1580	
Sound pressure level <sup>4</sup>		dB(A)	45/44/43/43/42/41/40		47/46/45/45/44/43/42	
	Net dimensions <sup>5</sup> (WxHxD)	mm	1280×660×203		1670×680×244	
	Packed dimensions (WxHxD)	mm	1379×744×296		1915×760×330	
	Net/Gross weight	kg	35/41		48/58	
Pipe connections	Liquid/Gas pipe	mm	Φ9.53/Φ15.9			
	Drain pipe	mm	OD Φ16			

Notes:

- Indoor temperature 27°C DB, 19°C WB; outdoor temperature 35°C DB; equivalent refrigerant piping length 7.5m with zero level difference.
- Indoor temperature 20°C DB; outdoor temperature 7°C DB, 6°C WB; equivalent refrigerant piping length 7.5m with zero level difference.
- Each model's 7 airflow rate options are listed in order, from highest to lowest.
- Each model's 7 sound pressure levels are listed in order from highest to lowest and correspond to the model's 7 airflow rate options (see Note 3).  
Floor standing: Sound pressure level is measured 1m in front and 1m above the floor in a semi-anechoic chamber.  
Ceiling mounted: Sound pressure level is measured 1m in front and 1m below the unit in a semi-anechoic chamber.
- Unit body dimensions given are the largest external dimensions of the unit, including hanger attachments.

# Floor Standing Unit (Concealed)

- Designed to be concealed in walls with only the suction and discharge grills visible



Optional wireless remote controller



WL-12D-CM

WL-12B-CM

Optional wired controller



WR-86KD-CM

WR-120G-CM

Model			42VS007H115003016	42VS009H115003016
Power supply			1 phase, 220-240V, 50Hz	
Cooling <sup>1</sup>	Capacity	kW	2.2	2.8
		kBtu/h	7.5	9.6
	Power input	W	40	45
Heating <sup>2</sup>	Capacity	kW	2.4	3.2
		kBtu/h	8.2	10.9
	Power input	W	40	45
Air flow rate <sup>3</sup>		m <sup>3</sup> /h	530/504/478/456/439/418/400	569/540/515/485/462/443/421
Sound pressure level <sup>4</sup>		dB(A)	36/35/34/33/31/30/29	36/35/34/33/31/30/29
Unit	Net dimensions <sup>5</sup> (W×H×D)	mm	840×545×212	
	Packed dimensions (W×H×D)	mm	925×639×305	
	Net/Gross weight	kg	21/25.5	
Pipe connections	Liquid/Gas pipe	mm	Φ6.35/Φ12.7	
	Drain pipe	mm	Φ16	

Model			42VS012H115003016	42VS016H115003016
Power supply			1 phase, 220-240V, 50Hz	
Cooling <sup>1</sup>	Capacity	kW	3.6	4.5
		kBtu/h	12.3	15.4
	Power input	W	55	60
Heating <sup>2</sup>	Capacity	kW	4.0	5.0
		kBtu/h	13.6	17.1
	Power input	W	55	60
Air flow rate <sup>3</sup>		m <sup>3</sup> /h	624/591/557/522/473/420/375	660/625/583/542/501/475/440
Sound pressure level <sup>4</sup>		dB(A)	37/36/35/34/32/31/30	37/36/35/34/32/31/30
Unit	Net dimensions <sup>5</sup> (W×H×D)	mm	1036×639×305	
	Packed dimensions (W×H×D)	mm	1125×639×305	
	Net/Gross weight	kg	25.5/30.5	
Pipe connections	Liquid/Gas pipe	mm	Φ6.35/Φ12.7	
	Drain pipe	mm	Φ16	

Model			42VS020H115003016	42VS024H115003016	42VS028H115003016
Power supply			1 phase, 220-240V, 50Hz		
Cooling <sup>1</sup>	Capacity	kW	5.6	7.1	8.0
		kBtu/h	19.1	24.2	27.3
	Power input	W	88	110	130
Heating <sup>2</sup>	Capacity	kW	6.3	8.0	9.0
		kBtu/h	21.5	27.3	30.7
	Power input	W	88	110	130
Air flow rate <sup>3</sup>		m <sup>3</sup> /h	1150/1094/1028/970/925/886/830	1380/1290/1205/1100/1033/955/870	1380/1290/1205/1100/1033/955/870
Sound pressure level <sup>4</sup>		dB(A)	41/39/37/35/33/32/31	44/42/40/39/37/35/33	44/42/40/39/37/35/33
Unit	Net dimensions <sup>5</sup> (W×H×D)	mm	1340×545×212		
	Packed dimensions (W×H×D)	mm	1425×639×305		
	Net/Gross weight	kg	30.5/35.5		32/37
Pipe connections	Liquid/Gas pipe	mm	Φ9.53/Φ15.9		
	Drain pipe	mm	Φ16		

## Notes:

1. Indoor temperature 27°C DB, 19°C WB; outdoor temperature 35°C DB; equivalent refrigerant piping length 7.5m with zero level difference.
  2. Indoor temperature 20°C DB; outdoor temperature 7°C DB, 6°C WB; equivalent refrigerant piping length 7.5m with zero level difference.
  3. Each model's 7 airflow rate options are listed in order, from highest to lowest.
  4. Each model's 7 sound pressure levels are listed in order from highest to lowest and correspond to the model's 7 airflow rate options (see Note 3). Sound pressure level is measured 1m in front and 1m above the floor in a semi-anechoic chamber.
  5. Unit body dimensions given are the largest external dimensions of the unit, including hanger attachments.
- All specifications are measured at 10Pa external static pressure.

# Floor Standing Unit (Exposed)

The F4 (front air intake) and F5 (underside air intake) offer a choice of air intake options

Optional wireless remote controller



WL-12D-CM WL-12B-CM

Optional wired controller



WR-86KD-CM WR-120G-CM



front air intake



underside air intake

Model		42VS007H115002016		42VS009H115002016	
		42VS007H115001016		42VS009H115001016	
Power supply		1 phase, 220-240V, 50Hz			
Cooling <sup>1</sup>	Capacity	kW	2.2	2.8	
		kBtu/h	7.5	9.6	
	Power input	W	40	45	
Heating <sup>2</sup>	Capacity	kW	2.4	3.2	
		kBtu/h	8.2	10.9	
	Power input	W	40	45	
Air flow rate <sup>3</sup>		m <sup>3</sup> /h	530/504/478/456/439/418/400		569/540/515/485/462/443/421
Sound pressure level <sup>4</sup>		dB(A)	36/35/34/33/31/30/29		36/35/34/33/31/30/29
Unit	Net dimensions <sup>5</sup> (W×H×D)	mm (F4)	1000×596×225		
		mm (F5)	1000×677×220		
	Packed dimensions (W×H×D)	mm (F4)	1089×683×312		
		mm (F5)	1182×683×312		
Net/Gross weight	kg (F4)	28/33			
	kg (F5)	28/35			
Pipe connections	Liquid/Gas pipe	mm	Φ6.35/Φ12.7		
	Drain pipe	mm	Φ16		

Model		42VS012H115002016		42VS016H115002016	
		42VS012H115001016		42VS016H115001016	
Power supply					
Cooling <sup>1</sup>	Capacity	kW	3.6	4.5	
		kBtu/h	12.3	15.4	
	Power input	W	55	60	
Heating <sup>2</sup>	Capacity	kW	4.0	5.0	
		kBtu/h	13.6	17.1	
	Power input	W	55	60	
Air flow rate <sup>3</sup>		m <sup>3</sup> /h	624/591/557/522/473/420/375		660/625/583/542/501/475/440
Sound pressure level <sup>4</sup>		dB(A)	37/36/35/34/32/31/30		37/36/35/34/32/31/30
Unit	Net dimensions <sup>5</sup> (W×H×D)	mm (F4)	1200×596×225		
		mm (F5)	1200×677×220		
	Packed dimensions (W×H×D)	mm (F4)	1289×683×312		
		mm (F5)	1382×683×312		
Net/Gross weight	kg (F4)	33/38.6			
	kg (F5)	33/40.7			
Pipe connections	Liquid/Gas pipe	mm	Φ6.35/Φ12.7		
	Drain pipe	mm	Φ16		

Model		42VS020H115002016		42VS024H115002016		42VS028H115002016	
		42VS020H115001016		42VS024H115001016		42VS028H115001016	
Power supply		1 phase, 220-240V, 50Hz					
Cooling <sup>1</sup>	Capacity	kW	5.6	7.1	8.0		
		kBtu/h	19.1	24.2	27.3		
	Power input	W	88	110	130		
Heating <sup>2</sup>	Capacity	kW	6.3	8.0	9.0		
		kBtu/h	21.5	27.3	30.7		
	Power input	W	88	110	130		
Air flow rate <sup>3</sup>		m <sup>3</sup> /h	1150/1094/1028/970/925/886/830		1380/1290/1205/1100/1033/955/870		1380/1290/1205/1100/1033/955/870
Sound pressure level <sup>4</sup>		dB(A)	41/39/37/35/33/32/31		44/42/40/39/37/35/33		44/42/40/39/37/35/33
Unit	Net dimensions <sup>5</sup> (W×H×D)	mm (F4)	1500×596×225				
		mm (F5)	1500×677×220				
	Packed dimensions (W×H×D)	mm (F4)	1589×683×312				
		mm (F5)	1682×683×312				
Net/Gross weight	kg (F4)	40/46					
	kg (F5)	40.4/48.6					
Pipe connections	Liquid/Gas pipe	mm	Φ9.53/Φ15.9				
	Drain pipe	mm	Φ16				

Notes:

- Indoor temperature 27°C DB, 19°C WB; outdoor temperature 35°C DB; equivalent refrigerant piping length 7.5m with zero level difference.
- Indoor temperature 20°C DB; outdoor temperature 7°C DB, 6°C WB; equivalent refrigerant piping length 7.5m with zero level difference.
- Each model's 7 airflow rate options are listed in order, from highest to lowest.
- Each model's 7 sound pressure levels are listed in order from highest to lowest and correspond to the model's 7 airflow rate options (see Note 3). Sound pressure level is measured 1m in front and 1m above the floor in a semi-anechoic chamber.
- Unit body dimensions given are the largest external dimensions of the unit, including hanger attachments.

# Console

- Combination of four air inlets and two air outlets ensures that cooling and heating are distributed in all directions.



Optional wireless remote controller



WL-12D-CM WL-12B-CM

Optional wired controller



WR-86KD-CM WR-120G-CM

Model			42VC007H115000016*	42VC009H115000016*	42VC012H115000016*	42VC016H115000016*
Power supply			1 phase, 220-240V, 50Hz			
Cooling <sup>1</sup>	Capacity	kW	2.2	2.8	3.6	4.5
		kBtu/h	7.5	9.6	12.3	15.4
	Power input	W	20	25	25	35
Heating <sup>2</sup>	Capacity	kW	2.6	3.2	4.0	5.0
		kBtu/h	8.9	10.9	13.4	17.1
	Power input	W	20	25	25	35
Air flow rate <sup>3</sup>		m <sup>3</sup> /h	430/401/374/345/302/268/229	510/482/456/430/355/286/229		660/614/561/512/478/436/400
Sound pressure level <sup>4</sup>		dB(A)	38/36/34/32/28/27/26	39/37/35/33/31/29/27		42/41/40/39/37/36/36
Unit	Net dimensions <sup>5</sup> (WxHxD)	mm	700×600×210			
	Packed dimensions (WxHxD)	mm	810×710×305			
	Net/Gross weight	kg	14/19	15/20		
Pipe connections	Liquid/Gas pipe	mm	Φ6.35/Φ12.7			
	Drain pipe	mm	OD Φ16			

**Notes:**

- Indoor temperature 27°C DB, 19°C WB; outdoor temperature 35°C DB; equivalent refrigerant piping length 7.5m with zero level difference.
- Indoor temperature 20°C DB; outdoor temperature 7°C DB, 6°C WB; equivalent refrigerant piping length 7.5m with zero level difference.
- Each model's 7 airflow rate options are listed in order, from highest to lowest.
- Each model's 7 sound pressure levels are listed in order from highest to lowest and correspond to the model's 7 airflow rate options (see Note 3).  
Sound pressure level is measured 1m in front and 1m above the floor in a semi-anechoic chamber.
- Unit body dimensions given are the largest external dimensions of the unit, including hanger attachments.

\* Available Q3 2019

# Floor Standing Unit (Exposed)

The F4 (front air intake) and F5 (underside air intake) offer a choice of air intake options

Optional wireless remote controller



WL-12D-CM WL-12B-CM

Optional wired controller



WR-86KD-CM WR-120G-CM



front air intake



underside air intake

Model		42VS007H115002016		42VS009H115002016	
		42VS007H115001016		42VS009H115001016	
Power supply		1 phase, 220-240V, 50Hz			
Cooling <sup>1</sup>	Capacity	kW	2.2	2.8	
		kBtu/h	7.5	9.6	
Heating <sup>2</sup>	Power input	W	40	45	
	Capacity	kW	2.4	3.2	
Heating <sup>2</sup>		kBtu/h	8.2	10.9	
	Power input	W	40	45	
Air flow rate <sup>3</sup>		m <sup>3</sup> /h	530/504/478/456/439/418/400		569/540/515/485/462/443/421
Sound pressure level <sup>4</sup>		dB(A)	36/35/34/33/31/30/29		36/35/34/33/31/30/29
Unit	Net dimensions <sup>5</sup> (W×H×D)	mm (F4)	1000×596×225		
		mm (F5)	1000×677×220		
	Packed dimensions (W×H×D)	mm (F4)	1089×683×312		
		mm (F5)	1182×683×312		
Net/Gross weight	kg (F4)	28/33			
	kg (F5)	28/35			
Pipe connections	Liquid/Gas pipe	mm	Φ6.35/Φ12.7		
	Drain pipe	mm	Φ16		

Model		42VS012H115002016		42VS016H115002016	
		42VS012H115001016		42VS016H115001016	
Power supply		1 phase, 220-240V, 50Hz			
Cooling <sup>1</sup>	Capacity	kW	3.6	4.5	
		kBtu/h	12.3	15.4	
Heating <sup>2</sup>	Power input	W	55	60	
	Capacity	kW	4.0	5.0	
Heating <sup>2</sup>		kBtu/h	13.6	17.1	
	Power input	W	55	60	
Air flow rate <sup>3</sup>		m <sup>3</sup> /h	624/591/557/522/473/420/375		660/625/583/542/501/475/440
Sound pressure level <sup>4</sup>		dB(A)	37/36/35/34/32/31/30		37/36/35/34/32/31/30
Unit	Net dimensions <sup>5</sup> (W×H×D)	mm (F4)	1200×596×225		
		mm (F5)	1200×677×220		
	Packed dimensions (W×H×D)	mm (F4)	1289×683×312		
		mm (F5)	1382×683×312		
Net/Gross weight	kg (F4)	33/38.6			
	kg (F5)	33/40.7			
Pipe connections	Liquid/Gas pipe	mm	Φ6.35/Φ12.7		
	Drain pipe	mm	Φ16		

Model		42VS020H115002016		42VS024H115002016		42VS028H115002016	
		42VS020H115001016		42VS024H115001016		42VS028H115001016	
Power supply		1 phase, 220-240V, 50Hz					
Cooling <sup>1</sup>	Capacity	kW	5.6	7.1	8.0		
		kBtu/h	19.1	24.2	27.3		
Heating <sup>2</sup>	Power input	W	88	110	130		
	Capacity	kW	6.3	8.0	9.0		
Heating <sup>2</sup>		kBtu/h	21.5	27.3	30.7		
	Power input	W	88	110	130		
Air flow rate <sup>3</sup>		m <sup>3</sup> /h	1150/1094/1028/970/925/886/830		1380/1290/1205/1100/1033/955/870		1380/1290/1205/1100/1033/955/870
Sound pressure level <sup>4</sup>		dB(A)	41/39/37/35/33/32/31		44/42/40/39/37/35/33		44/42/40/39/37/35/33
Unit	Net dimensions <sup>5</sup> (W×H×D)	mm (F4)	1500×596×225				
		mm (F5)	1500×677×220				
	Packed dimensions (W×H×D)	mm (F4)	1589×683×312				
		mm (F5)	1682×683×312				
Net/Gross weight	kg (F4)	40/46					
	kg (F5)	40.4/48.6					
Pipe connections	Liquid/Gas pipe	mm	Φ9.53/Φ15.9				
	Drain pipe	mm	Φ16				

Notes:

- Indoor temperature 27°C DB, 19°C WB; outdoor temperature 35°C DB; equivalent refrigerant piping length 7.5m with zero level difference.
- Indoor temperature 20°C DB; outdoor temperature 7°C DB, 6°C WB; equivalent refrigerant piping length 7.5m with zero level difference.
- Each model's 7 airflow rate options are listed in order, from highest to lowest.
- Each model's 7 sound pressure levels are listed in order from highest to lowest and correspond to the model's 7 airflow rate options (see Note 3). Sound pressure level is measured 1m in front and 1m above the floor in a semi-anechoic chamber.
- Unit body dimensions given are the largest external dimensions of the unit, including hanger attachments.



# Console

- Combination of four air inlets and two air outlets ensures that cooling and heating are distributed in all directions.



Optional wireless remote controller



WL-12D-CM WL-12B-CM

Optional wired controller



WR-86KD-CM WR-120G-CM

Model			42VC007H115000016*	42VC009H115000016*	42VC012H115000016*	42VC016H115000016*
Power supply			1 phase, 220-240V, 50Hz			
Cooling <sup>1</sup>	Capacity	kW	2.2	2.8	3.6	4.5
		kBtu/h	7.5	9.6	12.3	15.4
	Power input	W	20	25	25	35
Heating <sup>2</sup>	Capacity	kW	2.6	3.2	4.0	5.0
		kBtu/h	8.9	10.9	13.4	17.1
	Power input	W	20	25	25	35
Air flow rate <sup>3</sup>		m <sup>3</sup> /h	430/401/374/345/302/268/229	510/482/456/430/355/286/229		660/614/561/512/478/436/400
Sound pressure level <sup>4</sup>		dB(A)	38/36/34/32/28/27/26	39/37/35/33/31/29/27		42/41/40/39/37/36/36
Unit	Net dimensions <sup>5</sup> (WxHxD)	mm	700×600×210			
	Packed dimensions (WxHxD)	mm	810×710×305			
	Net/Gross weight	kg	14/19	15/20		
Pipe connections	Liquid/Gas pipe	mm	Φ6.35/Φ12.7			
	Drain pipe	mm	OD Φ16			

**Notes:**

1. Indoor temperature 27°C DB, 19°C WB; outdoor temperature 35°C DB; equivalent refrigerant piping length 7.5m with zero level difference.
2. Indoor temperature 20°C DB; outdoor temperature 7°C DB, 6°C WB; equivalent refrigerant piping length 7.5m with zero level difference.
3. Each model's 7 airflow rate options are listed in order, from highest to lowest.
4. Each model's 7 sound pressure levels are listed in order from highest to lowest and correspond to the model's 7 airflow rate options (see Note 3).  
Sound pressure level is measured 1m in front and 1m above the floor in a semi-anechoic chamber.
5. Unit body dimensions given are the largest external dimensions of the unit, including hanger attachments.

\* Available Q3 2019



# CONTROL SOLUTIONS

---

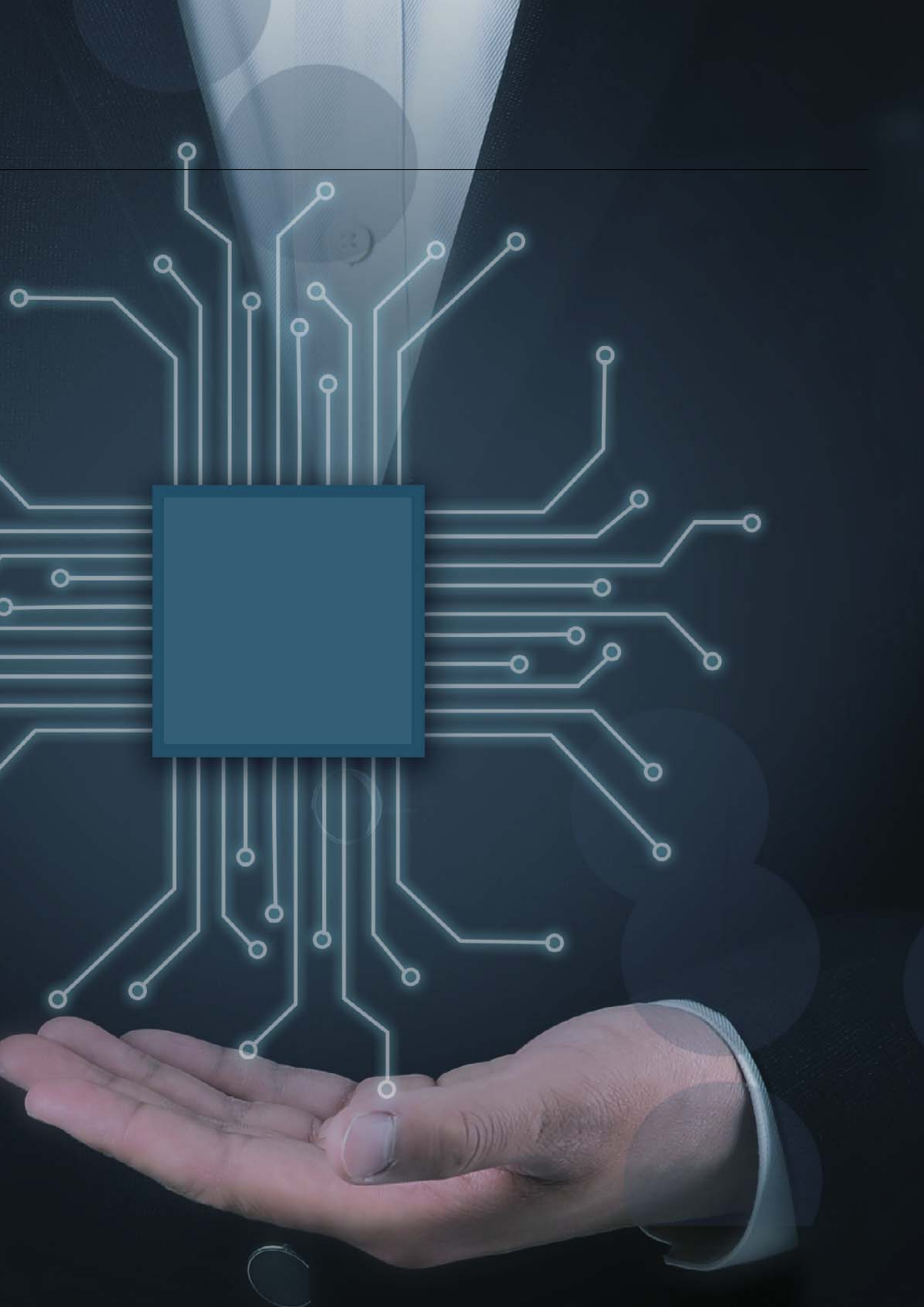



# CONTROLLER LINEUP

Wireless Remote Controllers	Wired Controllers	Centralized Controllers
<p data-bbox="256 562 400 589">WL-12B-CM</p> 	<p data-bbox="691 562 844 589">WR-86K-CM</p> 	<p data-bbox="1125 562 1295 589">CRF-180A-CM</p> 
<p data-bbox="296 999 440 1025">WL-12D-CM</p> 	<p data-bbox="703 999 874 1025">WR-86KD-CM</p> 	<p data-bbox="1137 999 1315 1025">CRF-270A-CM</p> 
	<p data-bbox="683 1397 847 1424">WR-120G-CM</p> 	

Network Control System	BMS Gateways	Accessories
------------------------	--------------	-------------

4GNS-20-CM



+

4GNS-20-IF



NW-BAC-CM



Hotel Key Card Interface Module



CA-NIM05/E



CA-NIM05B/E

GW-LON



Infrared Sensor Controller



CA-NIM09

CRF-270A-CM



+

4GNS-20-IF



NW-MOD-CM



Diagnosis software





VRF-DIAG-B

# Wireless Remote Controllers



## Features

Model	 WL-12B-CM	 WL-12D-CM
On / Off	●	●
Mode selection	●	●
Temperature setting	● (0.5°C or 1°C steps)	● (0.5°C or 1°C steps)
7-speed fan control	●	●
Auto swing	●	●
5-step swing louver	●	●
Address setting	●	●
Follow me	●	●
Eco mode	●	●
Night silent mode	●	●
Display shut-off	●	●
Daily timer	●	●
Keyboard lock	●	●
Background light	●	●
Dimensions (H W D) (mm)	150 65 20	170 48 20
Batteries	1.5V (LR03/AAA) 2	

## Temperature Setting

---

Set temperature can be adjusted in 0.5°C or 1°C steps, enabling precise comfort control.

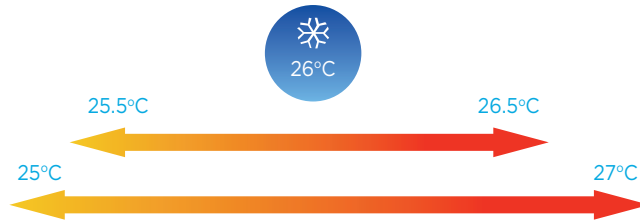

## 7-Speed Fan Control

---

7 indoor fan speeds provide control flexibility to meet the needs of different indoor conditions.

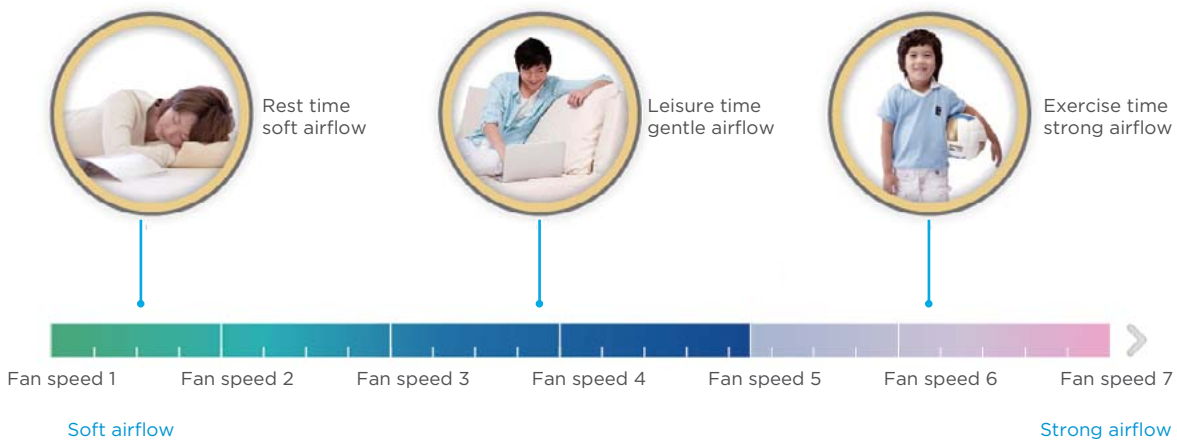

## Display Shut-off

---

Indoor unit displays can be shut off at night, creating a better environment for rest.





## 5-step Swing Louver

---

The air is comfortably spread upwards and downwards thanks to the 5-step swing louver that can be programmed via the controller.

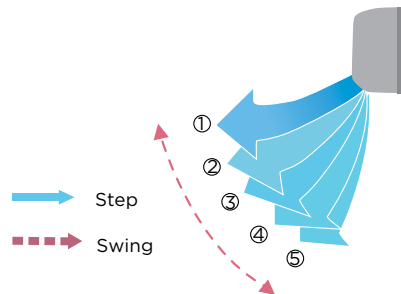

## Follow Me

---

With the follow me function, the indoor unit responds to the temperature measured by the temperature sensor built-in to the wireless remote controller, rather than the temperature sensor in the indoor unit itself, enabling more precise control of the temperature in the user's immediate environment.



## Eco Mode

---

Eco mode saves energy whilst retaining a comfortable indoor environment.



# Wired Controllers



## Features

Model	 <b>WR-86KD-CM</b>	 <b>WR-86K-CM</b>	 <b>WR-120G-CM</b>
On / Off	●	●	●
Mode selection	●	●	●
Temperature setting	● (0.5°C or 1°C steps)	● (0.5°C or 1°C steps)	● (0.5°C or 1°C steps)
Dual temperature set points	●	—	●
7-speed fan control	●	●	●
Auto swing	●	●	●
5-step swing louver	●	●	●
Address setting	●	●	●
Follow me	●	●	●
Eco mode	●	●	●
Room temperature display	●	—	●
°F/°C display	●	●	●
Keyboard lock	—	—	●
Background light	●	●	●
Daily timer	●	●	●
Weekly schedule timer	—	—	●
Auto restart	●	●	●
2 permission levels	—	—	●
Bi-directional communication	●	—	●
Group control	—	—	●
Main or secondary controller setting	●	—	●
Display shut-off	●	●	●
Night silent mode	●	●	●
Remote signal receiver	●	●	●
Clean filter reminder	●	●	●
Extension function	—	—	●
Daylight saving time	—	—	●
Clock display	—	—	●
Dot matrix display	—	—	●
Error check function	●	—	●
System parameter querying	●	—	●
System setting control	●	—	●
Dimensions (WxHxD) (mm)	86x86x18	86x86x18	120x120x20
Power supply	18 DC	5V DC	18 DC

## Group Control

One controller can be used to unify the settings across up to 16 indoor units.



## Main or Secondary Controller Setting

Two controllers can be used together, with the indoor units' operating mode and settings being set according to the most recent instruction received. The controller display screens are synchronized so that both displays update when a setting is adjusted.

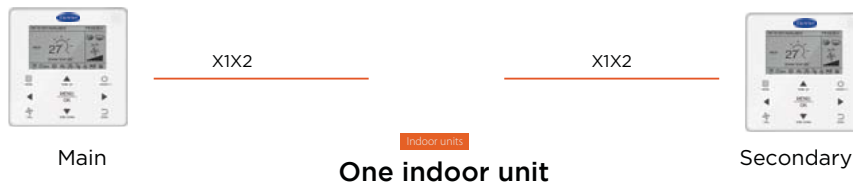

## 2 Permission Levels

2 permission levels ensure users can easily access control functions and allow administrators convenient access to operating parameters.

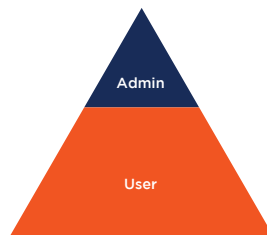

## Extension Function

The extension function is specifically designed for users working overtime. Pressing the delay button postpones system shutdown by 1 or 2 hours.



## Dual Temperature Set Points

With dual temperature set point control, the set temperature changes automatically when the operating mode is changed.

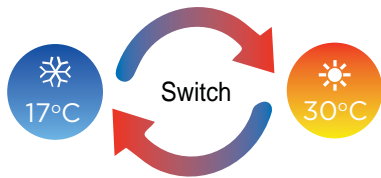

## Weekly Schedule Timer

The weekly schedule timer allows users to set multiple schedules each with its own operating mode, temperature settings and fan speeds.

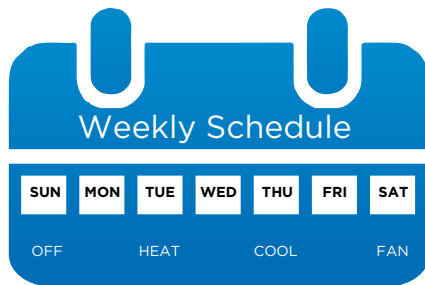

## Bi-directional Communication

The wired controller can query the system operating parameters thanks to the new bi-directional communication functionality. In addition, settings including static pressure, cold draft prevention and temperature compensation can be configured on the wired controller.



# Centralized Controllers



# Features

Model	 CRF-180A-CM	 CRF-270A-CM
Max. number of indoor units	64	384
Max. number of outdoor units	32	192
Max. number of refrigerant systems	8	48
Touch screen	● (6.2-inch)	● (10.1-inch)
On / Off	●	●
Mode selection	●	●
Temperature setting	● (0.5°C or 1°C steps)	● (0.5°C steps)
Dual temperature set points	●	●
7-speed fan control	●	●
Auto swing	●	●
5-step swing louver	●	●
Room temperature display	—	●
Outdoor unit Eco mode setting	●	●
Holiday setting	●	●
°C/°F display	●	●
Schedule management	●	●
Clock display	●	●
2 permission levels	●	●
Extension function	●	—
Unit model recognition	●	●
Electricity charge distribution	—	●
Visual schematic	—	●
Energy management	●	●
Group management	●	●
Error check function	●	●
System parameter querying	●	—
USB output	Error report	Error report, operation record and electricity consumption report
Report display		
Operation log	—	●
LAN access	—	●
languages supported	English, French, Spanish	English, French, Spanish
Dimensions (W H D) (mm)	182x123x34	270x183x27
Power supply	12V DC	24V AC

## Touch Screen

---

Colorful touch screen and vivid display make operation more convenient and simple.



## Electricity Charge Distribution

---

The controllers estimate the electricity consumption of the outdoor units and then divide it among the indoor units so that the electricity charges can be equitably divided among building occupants.

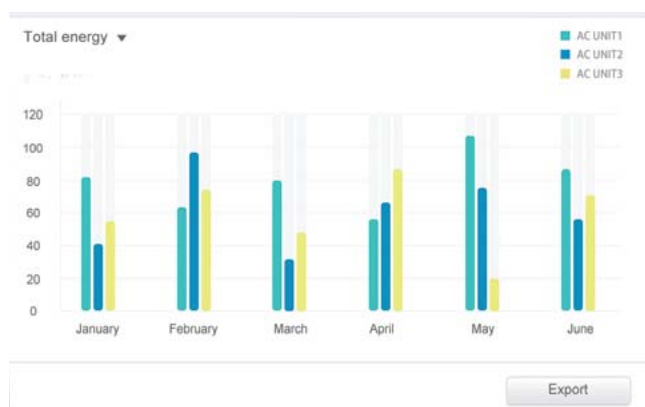

## Energy Management

---

User can set limits or locks on an indoor unit, such as minimum cooling temperature, maximum heating temperature, fan speed, operation mode, swing lock, remote controller lock and wired controller lock.





## Visual Schematic

By importing floor plans and then dragging and dropping the indoor units to their actual positions on the floor plan, users can create a tailored system schematic which enables monitoring and control of the indoor units through a clear visual representation of the system layout.



## Group Management

Units can be viewed according to group, system or location, making unit management clearer and more convenient.



## Outdoor Unit Configuration

Outdoor unit configuration and settings can be monitored and controlled without having to go outdoors.



## Unit Model Recognition

---

The controller recognizes the model of indoor and outdoor units and different models are represented by different icons.

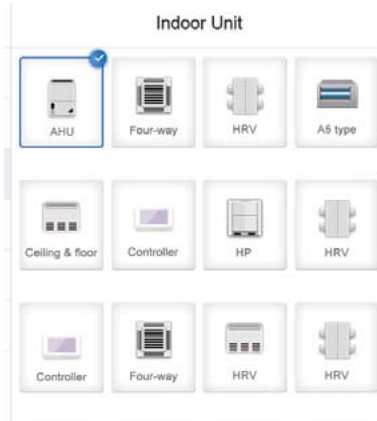

## Schedule Management

---

Daily, weekly or annual schedules can be used to set unit settings such as on/off, operating mode, set temperature, fan speed and swing.

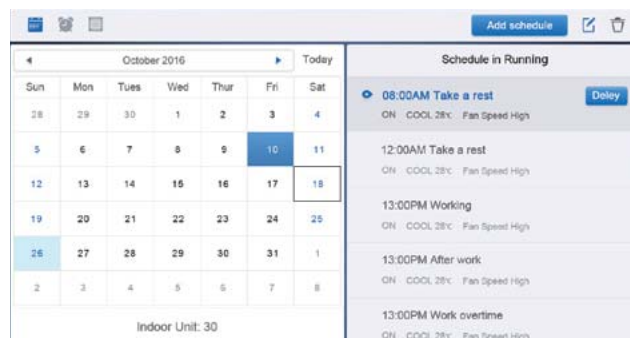

## LAN Access

---

A desktop or laptop PC can be used for browser-based access via a LAN connection.



# Wiring Flexibility

The controllers can be connected to the master outdoor unit directly.

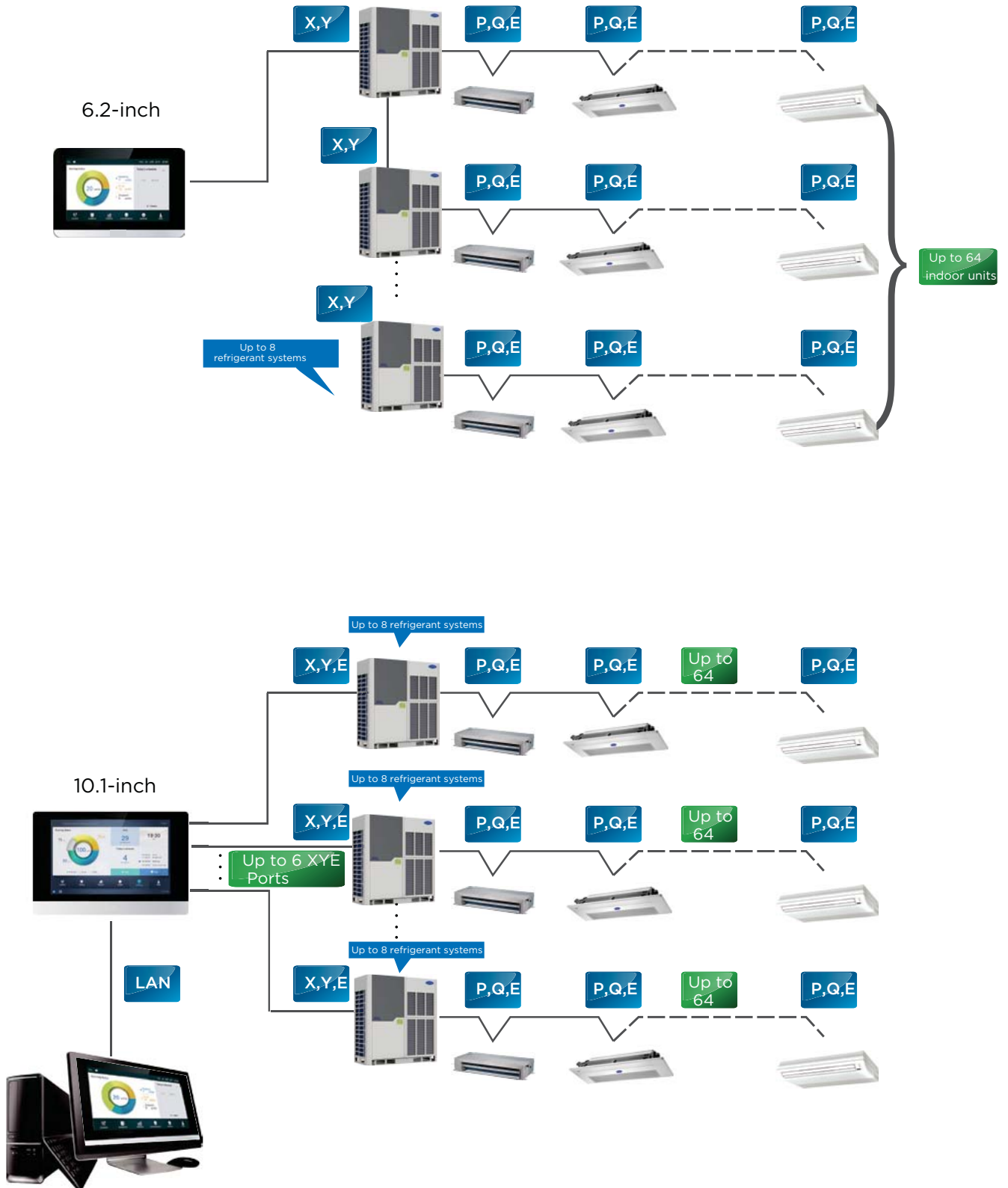



CONTROL SOLUTIONS

# Network Control System



# Features

Software model	4GNS-20-IF	
Hardware model	 4GNS-20-CM	 CRF-270A-CM
Max. number per IMM system	10	10
Max. number of indoor units	2560	3840
Max. number of outdoor units	1280	1920
Max. number of refrigerant systems	320	480
Temperature setting	● (0.5°C steps)	● (0.5°C steps)
Dual temperature set points	●	●
7-speed fan control	●	●
Auto swing	●	●
5-step swing louver	●	●
Outdoor unit Eco mode setting	●	●
Holiday setting	●	●
Schedule management	●	●
Clock display	●	●
2 permission levels	●	●
Unit model recognition	●	●
Electricity charge distribution	●	●
Visual schematic	●	●
Energy management	●	●
Group management	●	●
Error check function	●	●
System parameter querying	●	●
Report output	●	●
Operation log	●	●
LAN access	●	●
Data backup	●	●
Remote VPN access	●	●
Languages supported	English, French, Spanish	English, French, Spanish
Dimensions (W H D) (mm)	251x319x66	270x183x27
Power supply	1 phase, 100-240V, 50/60Hz	24V AC

## User-friendly Interface

---

Simple, practical user interface makes for a user-friendly experience even for first-time users.



## Outdoor Unit Configuration

---

Outdoor unit configuration and settings can be monitored and controlled without having to go outdoors.

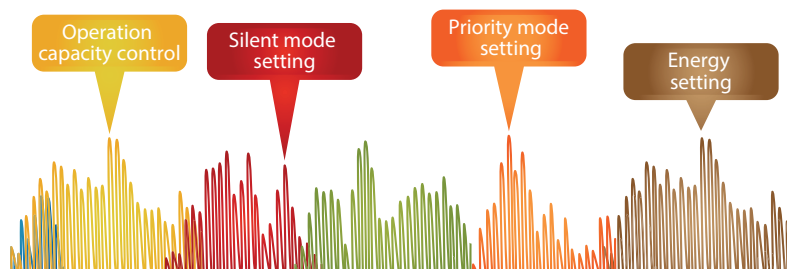

## Electricity Charge Distribution

---

The IMMPRO uses the Calculation Method to estimate the electricity consumption of the outdoor units and then divide it among the indoor units so that the electricity charges can be equitably divided among building occupants.



# Public and Idle Devices

Marking a unit as a public device or idle device ensures the electricity charge distribution is more accurate and reasonable.

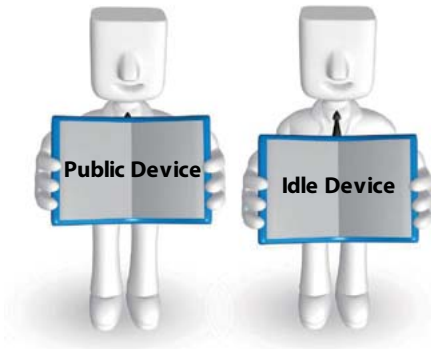

# Visual Schematic

By importing floor plans and then dragging and dropping the indoor units to their actual positions on the floor plan, users can create a tailored system schematic which enables monitoring and control of the indoor units through a clear visual representation of the system layout.



# Schedule Management

Daily, weekly or annual schedules can be used to set unit settings such as on/off, operating mode, set temperature, fan speed and swing.



# Xpress Installation

With the Xpress Installation wizard, IMMPRO can be installed quickly and easily without requiring support from a technical support engineer.



# Network Flexibility

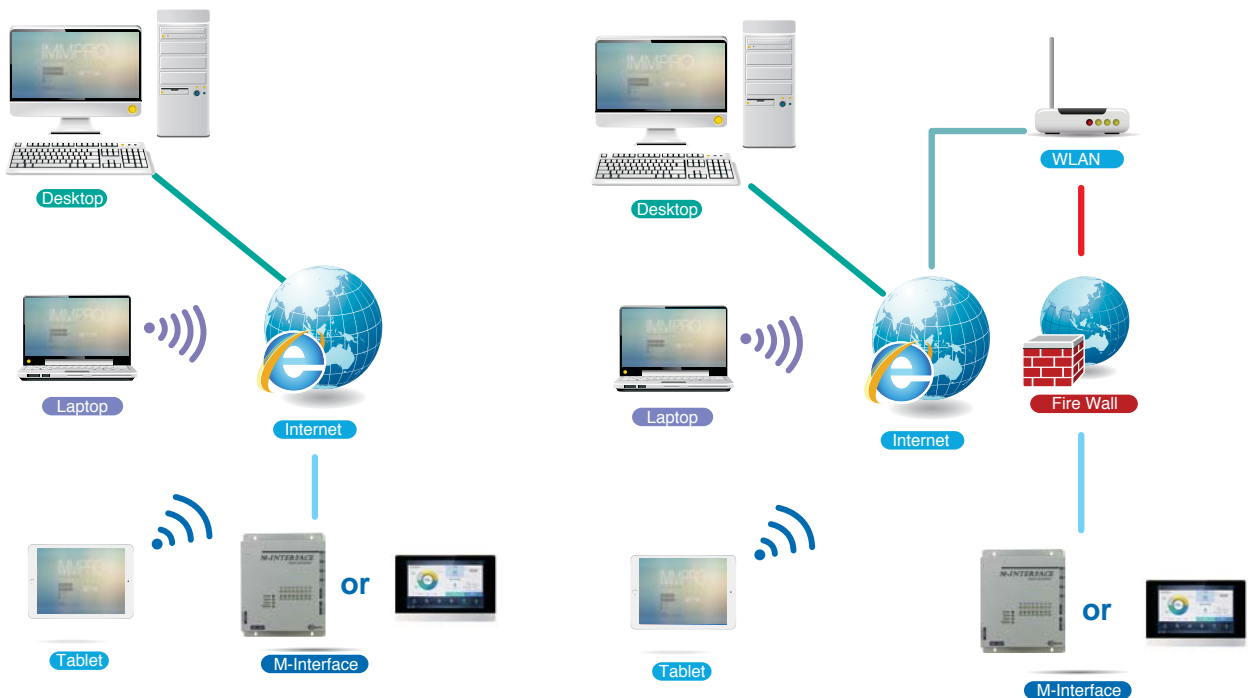

LAN access

Remote VPN access



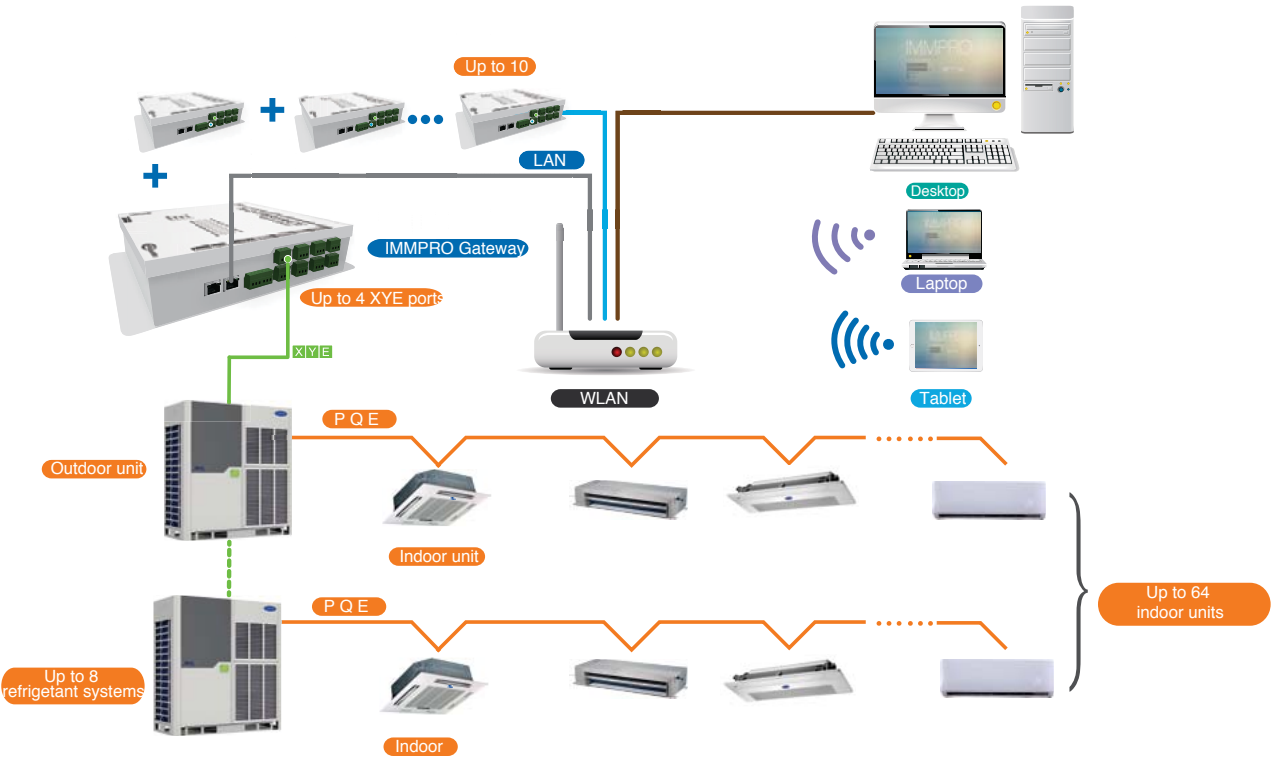

4GNS-20-CM

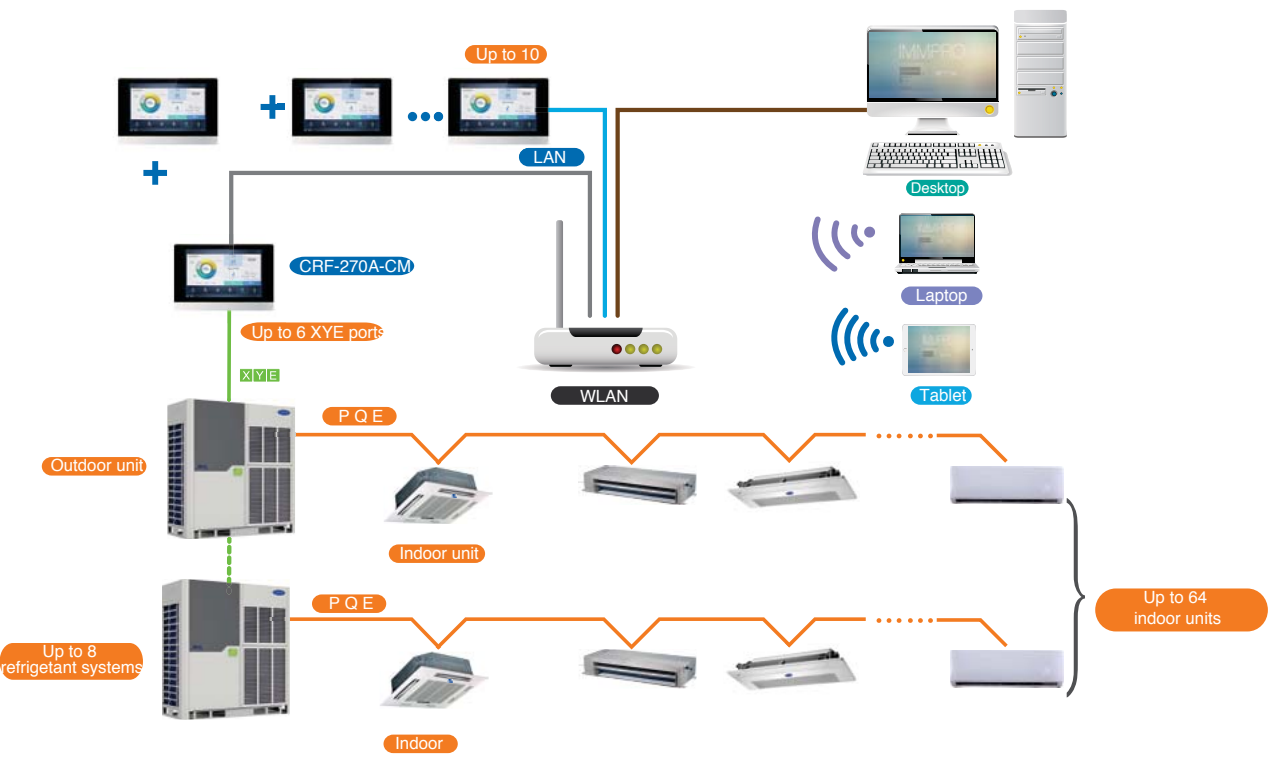

CRF-270A-CM

# BMS Gateway

Monitoring and control of Carrier's VRF air conditioners can be integrated into building management systems, enabling air conditioning to be monitored alongside lighting, power, fire, access and security systems. Carrier's gateway devices provide full compatibility with the leading BMS protocols: BACnet, LonWorks and Modbus.





招商银行

上海银行  
Bank of Shanghai



NW-BAC-CM

## BACnet® Gateway

### Full Integration

The NW-BAC-CM Gateway allows Carrier VRF systems to be monitored and controlled alongside other building management technology that use the BACnet protocol such as access control, fire detection and lighting systems.

### Network Flexibility

The gateway can be connected to master outdoor units' XYE ports directly.

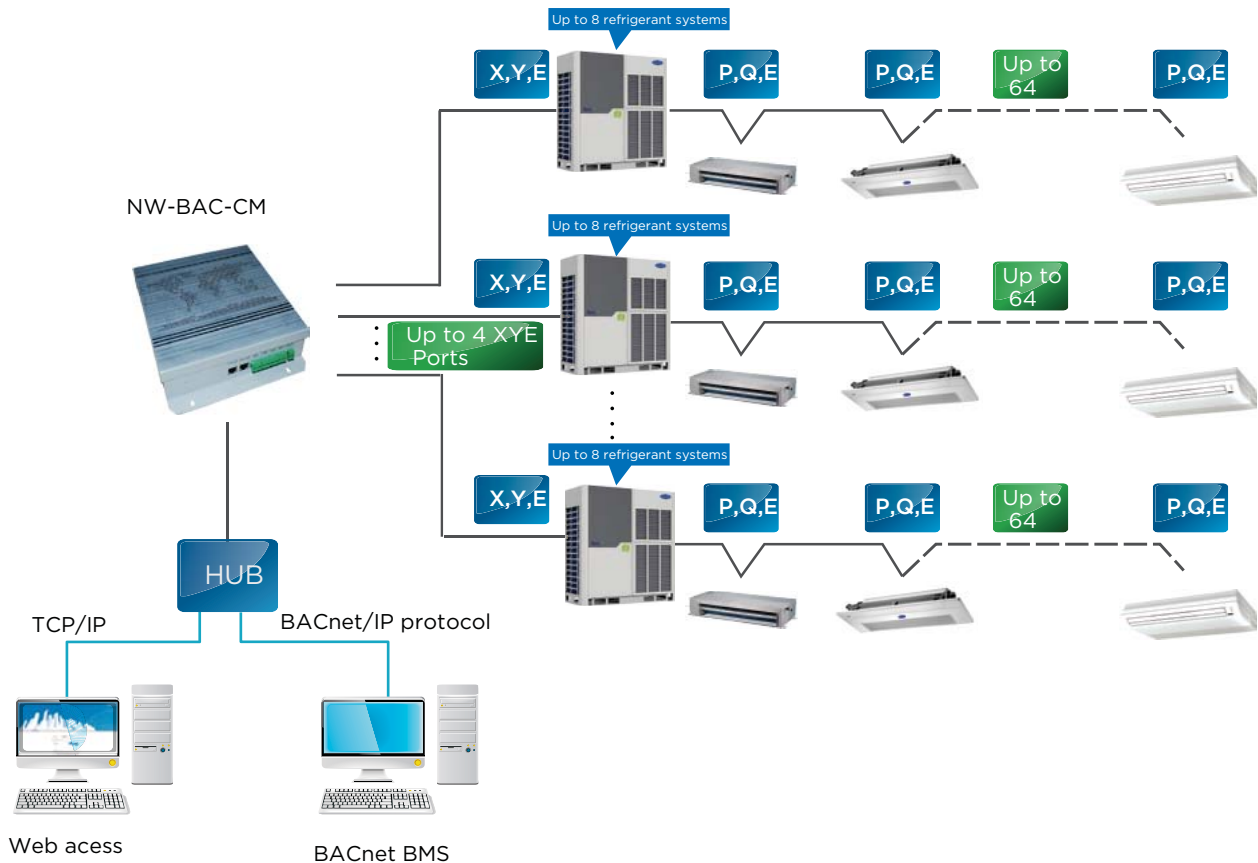

## Features

Model	NW-BAC-CM	
Max. number of indoor units		256
Max. number of outdoor units		128
Max. number of refrigerant systems		32
<b>Control</b>	On / Off	●
	Mode selection	●
	Temperature setting	●
	Fan speed	●
	Energy management	●
<b>Indoor unit monitoring</b>	Room temperature display	●
	Error status	●
	Error alarms	●
<b>Outdoor unit monitoring</b>	Operating mode	●
	Outdoor ambient temperature	●
	Fan speed	●
	Compressor operating frequency	●
	Discharge temperature	●
	System pressure	●
	Error status	●
	Error alarms	●
LAN access		●
BTL certification		●
<b>Compatibility</b>	Siemens	APOGEE
	Trane	TRACER
	Honeywell	ALERTON
	Schneider	Andover Continuum
	Johnson Controls	METASYS
Dimensions (HxWxD)( mm)		319x251x61
Power supply		1 phase, 100-240V, 50/60Hz



NW-LON-CM

## LonWorks® Gateway

### Full Integration

The NW-LON-CM Gateway allows Carrier VRF systems to be monitored and controlled alongside other building management technology on the LonWorks platform such as security, fire safety and lighting systems.

### Network Flexibility

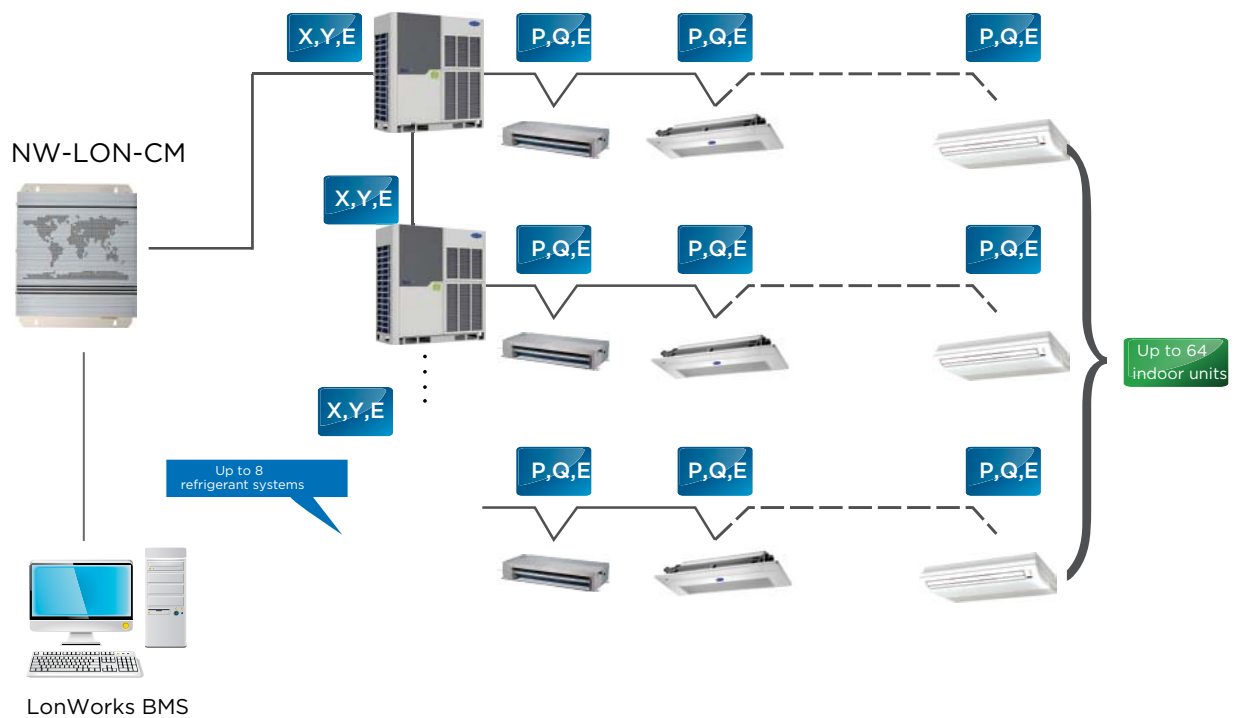

## Features

Model	NW-LON-CM	
Max. number of indoor units		64
Max. number of outdoor units		32
Max. number of refrigerant systems		8
Control	Mode selection	●
	Temperature setting	●
	Fan speed	●
	Group shut down	●
	On / Off	●
Indoor unit monitoring	Operating mode	●
	Set temperature	●
	Fan speed	●
	Online status	●
	Operating status	●
	Room temperature	●
	Error status	●
Outdoor unit monitoring	Error status	●
Dimensions (HxWxD)( mm)		319x251x61
Power supply		1 phase, 100-240V, 50/60Hz



NW-MOD-CM

# Modbus® Gateway

## Full Integration

The NW-MOD-CM Gateway enables seamless connection of Carrier VRF systems with building management systems built on the Modbus communication protocol.

## Network Flexibility

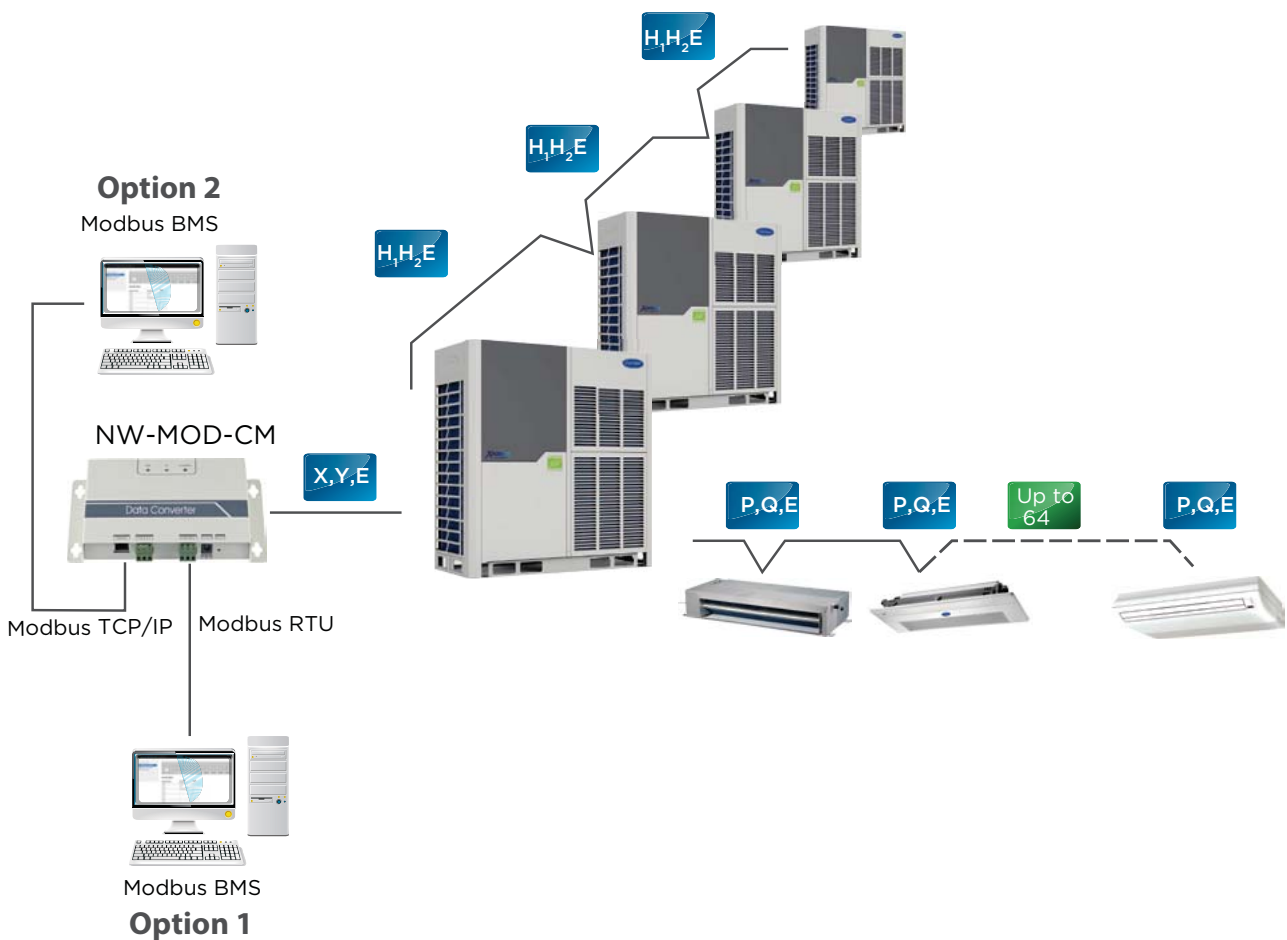



## Features

Model	NW-MOD-CM	
Max. number of indoor units		64
Max. number of outdoor units		4
Max. number of refrigerant systems		1
Control	On / Off	●
	Mode selection	●
	Temperature setting	●
	Fan speed	●
	Group on/off	●
Indoor unit monitoring	Online status	●
	Room temperature	●
	Error status	●
	Operating mode	●
Outdoor unit monitoring	Operating mode	●
	Lock status	●
	Fan speed	●
	Set temperature	●
	Outdoor ambient temperature	●
	Error status	●
LAN access		●
Dimensions (HxWxD)( mm)		319x251x61
Power supply		1 phase, 100-240V, 50/60Hz

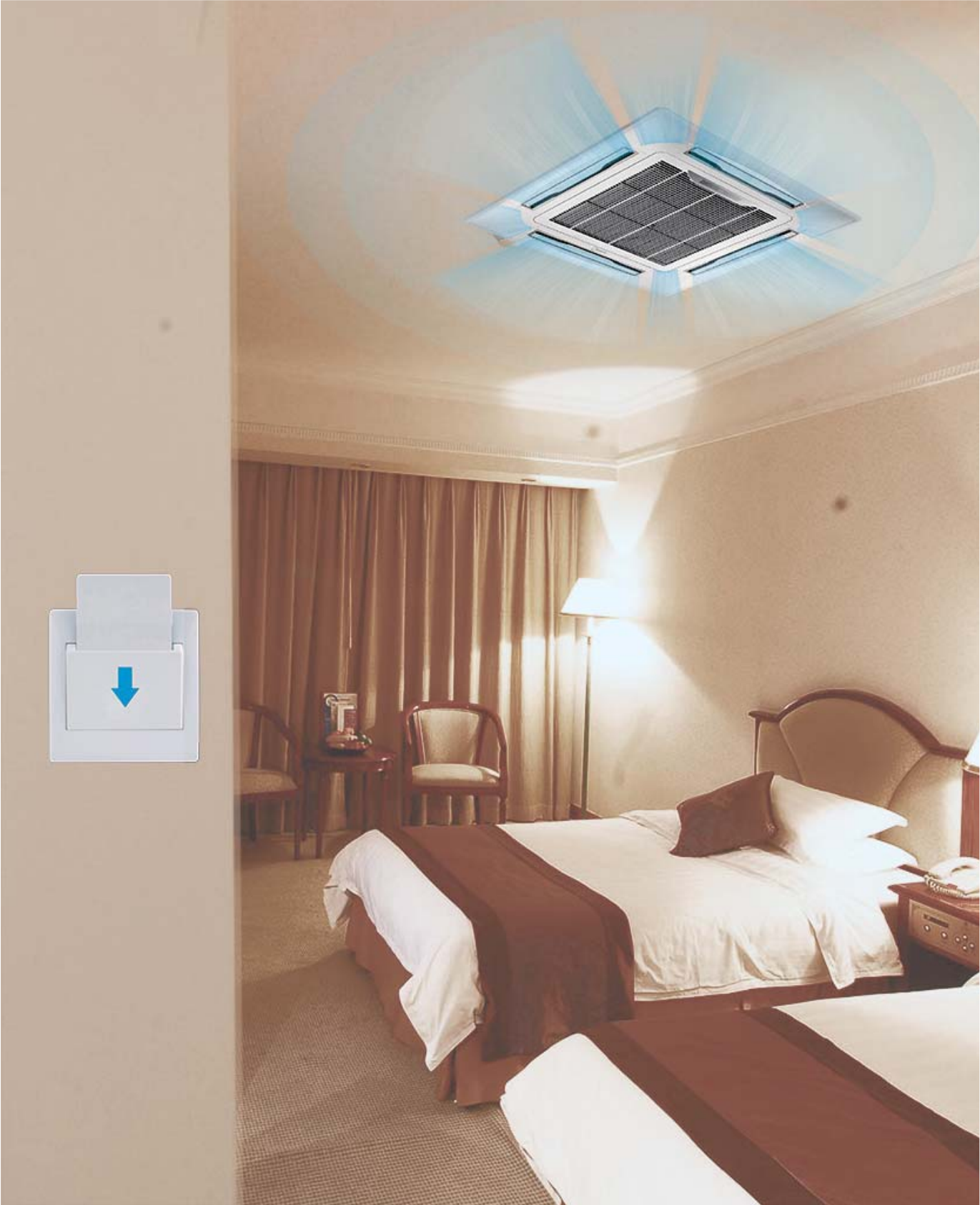

# Hotel Key Card Interface Modules



## Full Integration

The Hotel Key Card Interface Modules enable power supply to indoor units to be integrated with hotel key card power supply management systems, which are designed to save energy by only running appliances whilst guests are present in their room.

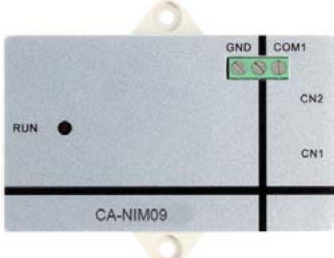
## Features

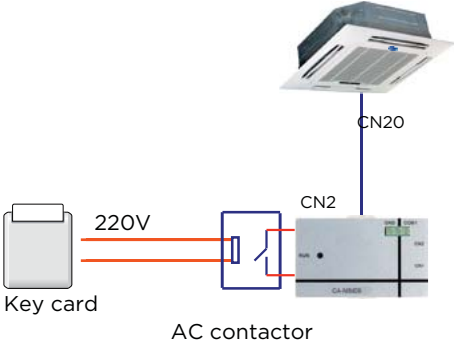
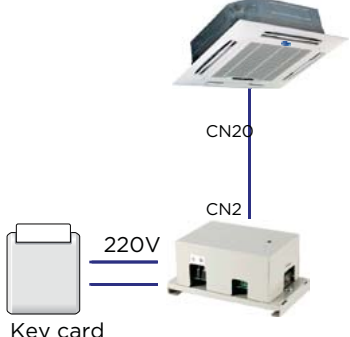
Model	CA-NIM05/E	CA-NIM05B/E
Appearance		
Network flexibility		
Auto restart	●	●
Compatibility	Remote and wired controller	Remote and wired controller
Dimensions (HxWxD) (mm)	15.5x86x72.8	87x150x70
Power supply	5V DC (Supplied by indoor unit)	1 phase, 100-240V, 50/60Hz

# Infrared Sensor Controller

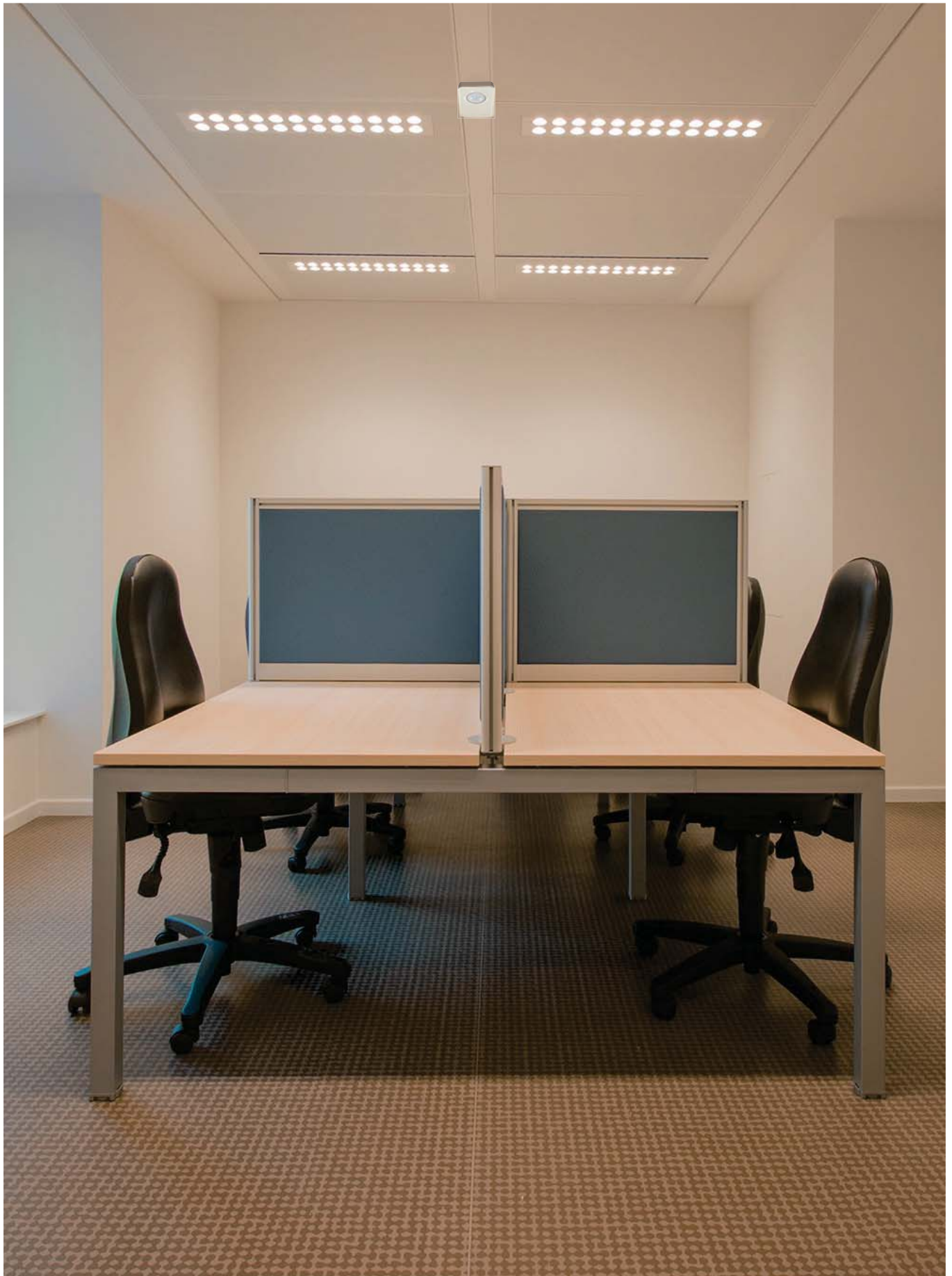

## Full Integration

Using infrared sensors to detect movement, the CA-NIM09 Infrared Sensor Controller automatically turns indoor units on or off upon sensing that the room is occupied or unoccupied. Suitable for hotels, offices, conference rooms and residences, the Infrared Sensor Controller ensures climate control whilst minimizing energy consumption.

### Features

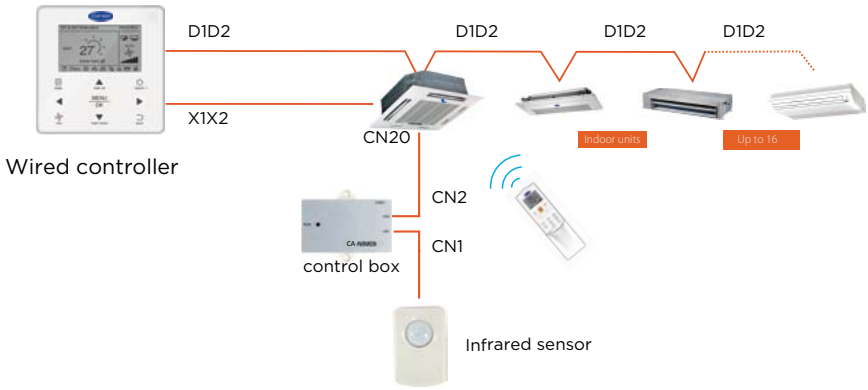
Model	CA-NIM09
Appearance	
Network flexibility	
Dimensions (HxWxD)(mm)	Sensor 46x30x25.6, Control box 86x72.8x15.5
Power supply	5V DC (Supplied by indoor unit)

# Diagnosis Software



# Monitor and Diagnose

Carrier's VRF Diagnosis Software tool is used to monitor VRF systems and diagnose system errors. System settings and operating parameters can be accessed easily and data logs can be reviewed for fault prevention purposes.

## Features

Model	VRF-DIAG-B	
Max. number of indoor units		64
Max. number of outdoor units		4
Max. number of refrigerant systems		1
Control	Mode selection	●
	Temperature setting	●
	Fan speed	●
Outdoor unit monitoring	Operating mode	●
	Capacity	●
	Compressor operating frequency	●
	Operating current	●
	Error status	●
	Temperatures	T3,T4,Tp (See note 1)
	Valve statuses	SV2, SV4, SV5, SV6, ST1 (See note 2)
	EXV position	●
Indoor unit monitoring	Operating mode	●
	Capacity	●
	Fan speed	●
	Address	●
	Temperatures	T1, T2, T2B, TS (See note 3)
	EXV position	●
Error codes		●
Troubleshooting		●
Data logs		●
Diagrams	System schematic, refrigerant flow diagram, parameter chart	
Languages supported	English, French, Spanish	

## Expert Diagnosis

---

Carrier's VRF Diagnosis Software is specially designed to allow after-sales engineers, to understand the operating status of the system at a glance.



## Use-friendly Interface

---

A stylish and simple interface with rich graphical representations makes diagnosing system issues quick and convenient.



## Diagrams

---

A system schematic, refrigerant flow diagram and parameter chart can be generated to provide a graphical interpretation of the system status.

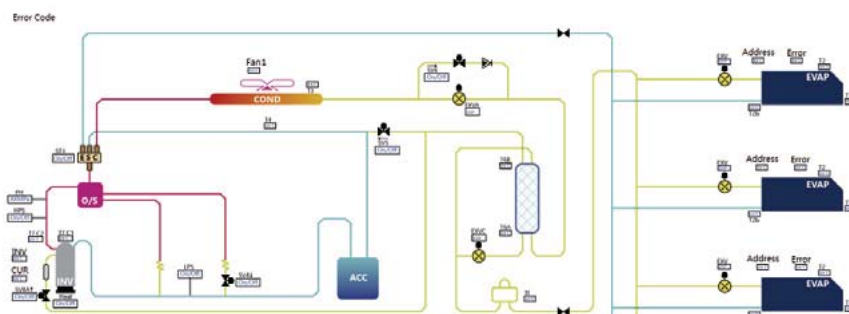



## Parameter Querying

---

Access all the system parameters easily.



## Data Logs

---

Data logs including operating records and error reports are saved by the software which is useful for discovering system issues.



## Wiring Schematic

---

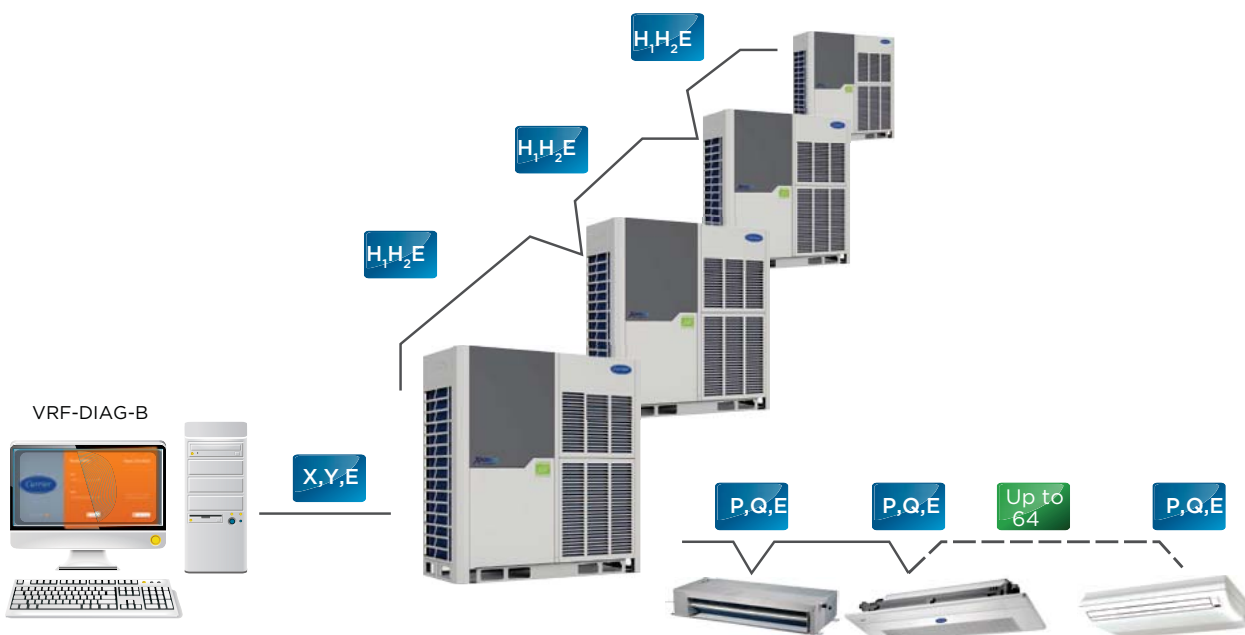

# VRF AHU Control Box

## High Efficiency

---

AHU kit facilitates raising the EER/COP of the complete AHU system.



## Wide Capacity Range

---

Four kits can be used in parallel, giving an overall capacity range of 3.2HP to 80HP.



AHUKZ-01B  
3.2-6HP



AHUKZ-02B  
8-12HP



AHUKZ-03B  
14-20HP

## Compatible with All VRF Systems

---

AHU kits are compatible with all Carrier VRF outdoor units and can be used together with all types of Carrier VRF indoor units.



## Single AHU Control Box Connection

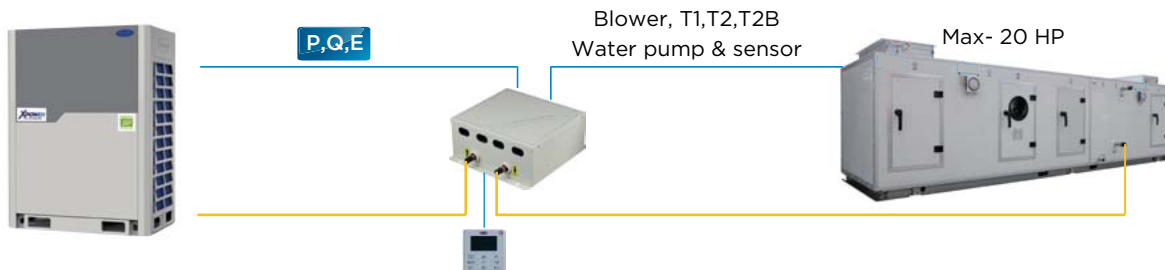

## Multi AHU Control Boxes Connection

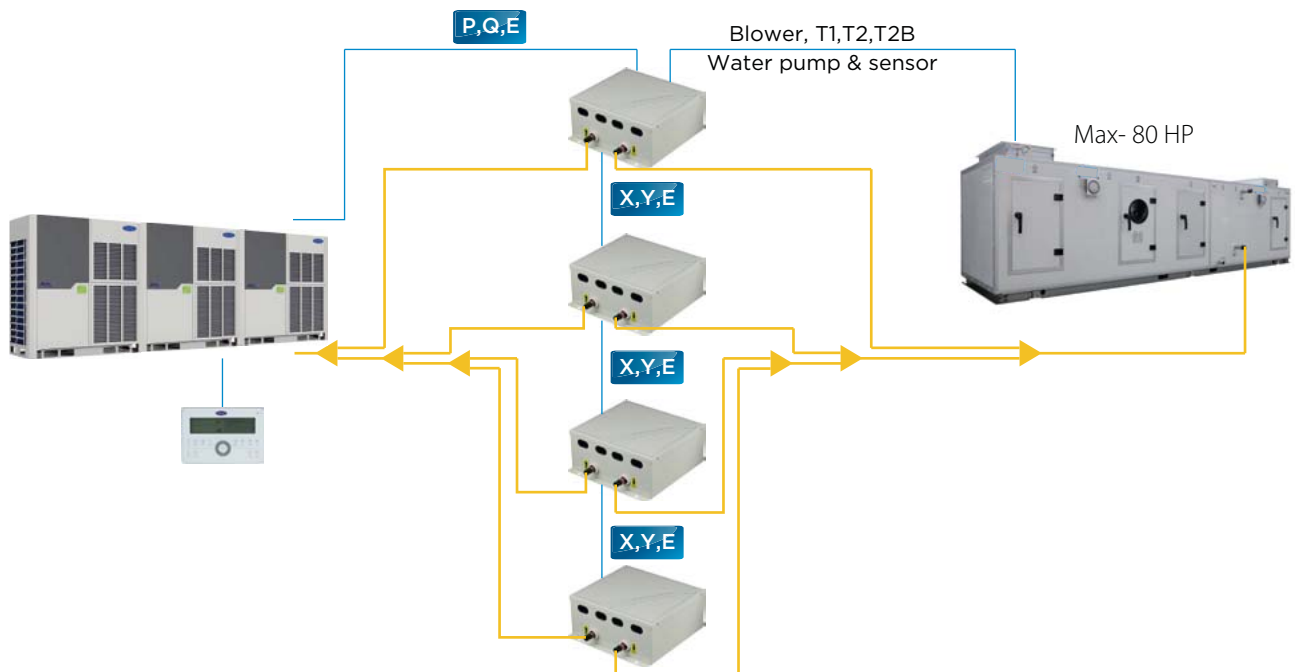

## Specifications

Model		AHUKZ-01B	AHUKZ-02B	AHUKZ-03B
Capacity	HP	3.2-6	8-12	14-20
Power supply		1 phase, 208-230V, 60Hz		
Refrigerant		R410A		
Pipe connections (inlet and outlet)	mm	Φ8	Φ12.7	Φ15.9
Net dimensions (W×H×D)	mm	350×150×375		
Packed dimensions (W×H×D)	mm	420×240×490		
Net weight	kg	8.4	8.7	8.9
Gross weight	kg	11.4	11.7	11.9
Operating modes		Cooling, heating and fan only		
Standard controller		Wired controller		
Optional controller		Wireless remote controller; SIEMENS controller		

# Selection Software

## High Efficiency

Carrier's advanced design automation tool can be used by designers, consultants and distributors to greatly reduce the time and effort that must be devoted to the selection process. The software provides quick and convenient selectable options for users, supports multiple languages, and greatly improves the selection process.

The Selection Software provides distributors' sales team with a comprehensive selection of system design reports and calculations. Load calculations may be on either an initial estimate basis or detailed room-by-room basis. Based on the indoor units, outdoor units and controllers selected, the software produces detailed system layout diagrams and piping requirement calculations.

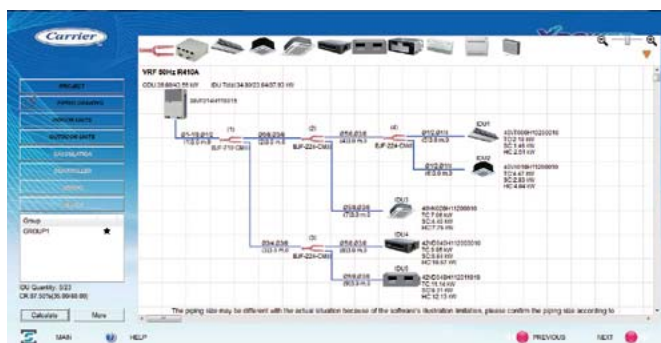

Piping diagram

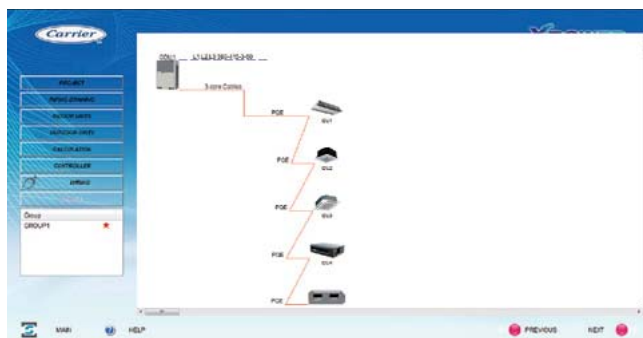

Wiring diagram

# Selection Software

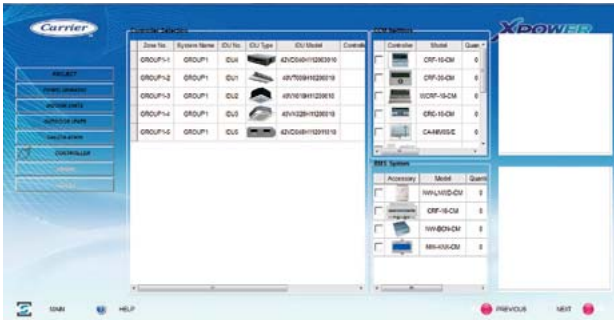

Controller selection

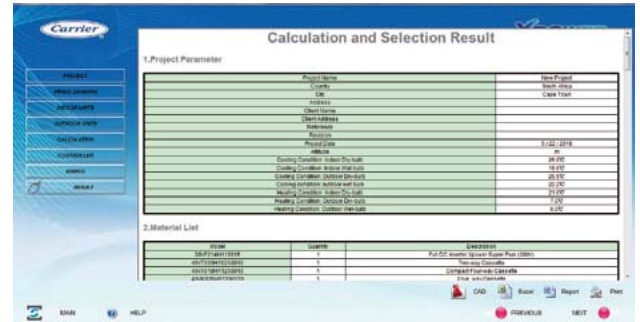

Report

# HEAT RECOVERY VENTILATOR

## Fan Motor Options

DC fan versions available.

## Enhanced Efficiency

The Carrier heat recovery ventilator (HRV) can greatly reduce energy losses and room temperature fluctuations caused by the ventilation process. The Carrier HRV's strong performance is a result of the advanced technology incorporated into its design. The heat exchanger core is made of specially treated paper which gives enhanced temperature and humidity control. Temperature exchange efficiency is over 65% and enthalpy exchange efficiency is 50-65%.



HRV-200 D(A)    HRV-500 D(A)  
HRV-300 D(A)    HRV-800 D(A)  
HRV-400 D(A)    HRV-1000 D(A)



HRV-1500 D(A)  
HRV-2000 D(A)

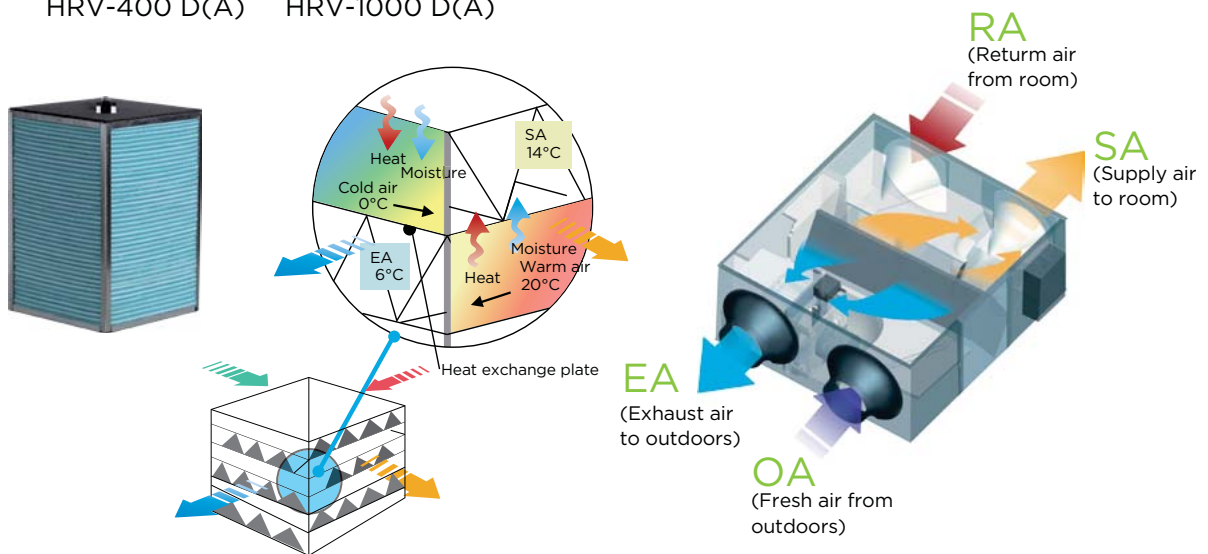

## Low Noise

Soundproofing is used to guarantee quiet operation.

## Flexibility

Heights starting from as little as 264mm and weights from as little as 23kg mean that the Carrier HRV can be easily installed even where space is limited.

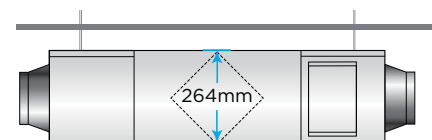

# Multiple Modes

## Heat exchange mode

The flows of incoming and outgoing air pass close to each other, allowing heat transfer between the two channels. During summer, incoming air is cooled by the indoor air being exhausted and in winter, incoming air is warmed.

## Bypass mode

In mild climates or seasons, where temperature and humidity differences between indoors and outdoors are small, the HRV can work as a conventional ventilation fan. In standard bypass mode the supply and exhaust fans run at the same speed.

## Air supply mode

Air supply mode is a form of bypass mode where the supply fan is set to run faster than the exhaust fan, which is useful in mild climate installations with high fresh air ventilation requirements.

## Exhaust mode

Exhaust mode is a form of bypass mode where the exhaust fan is set to run faster than the supply fan, which is useful in mild climate installations with large amounts of exhaust air to be expelled.

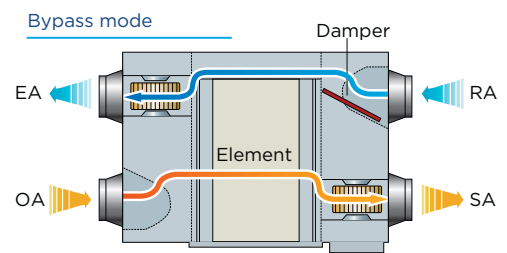
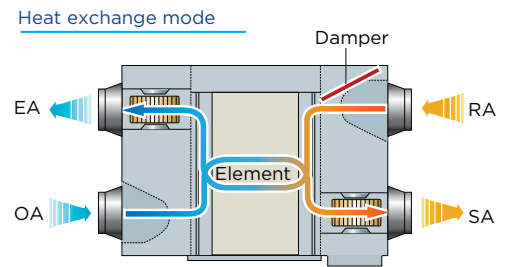

## Auto mode

The controller chooses heat exchange mode or bypass mode according to the temperature difference between outdoors and indoors. Both fans are set to run at low speed.

# Flexible Control

HRV can be controlled together with other indoor units.

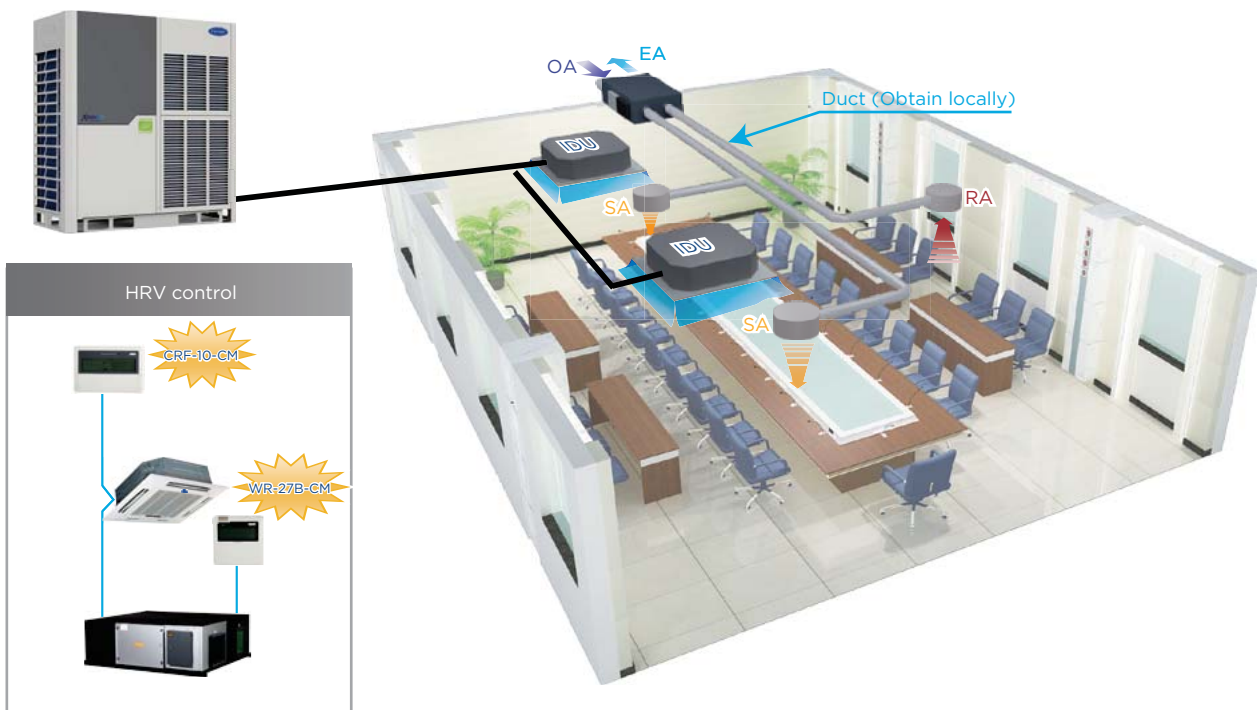

# Specifications

## DC Series

Model		HRV-200 D(A)	HRV-300 D(A)	HRV-400 D(A)	HRV-500 D(A)
Power supply	V/Ph/Hz	220-240/1/50(60)			
Cooling temp. exchange efficiency	%	76.1	74.8	76.2	76.1
Cooling enthalpy exchange efficiency	%	77.3	76.1	78.7	78.2
Heating temp. exchange efficiency	%	76.1	74.8	76.2	76.1
Heating enthalpy exchange efficiency	%	82.6	79.8	83.6	80.4
Sound pressure level	dB(A)	27	30	32	35
Airflow rate	m <sup>3</sup> /h	200	300	400	500
External static pressure	Pa	75	75	80	80
Motor type		DC			
Duct diameter	mm	Φ144	Φ144	Φ144	Φ194
Net dimensions (WxDxH)	mm	852×665×264	928×734×270	928×940×270	1020×1036×270
Packed dimensions (WxDxH)	mm	910×710×430	980×774×435	1010×1010×440	1120×1120×452
Net weight	kg	25	27	32	35
Gross weight	kg	37	40	46	51
Operating temperature range	°C	-7 to 43 DB, RH 80% or lower			



Model		HRV-800 D(A)	HRV-1000 D(A)	HRV-1500 D(A)	HRV-2000 D(A)
Power supply	V/Ph/Hz	220-240/1/50(60)			
Cooling temp. exchange efficiency	%	76.9	75.8	77.8	77.2
Cooling enthalpy exchange efficiency	%	78.1	76.9	79.2	78.7
Heating temp. exchange efficiency	%	76.9	75.8	77.8	77.2
Heating enthalpy exchange efficiency	%	80.1	78.6	80.5	80.3
Sound pressure level	dB(A)	39	40	51	53
Airflow rate	m <sup>3</sup> /h	800	1000	1500	2000
External static pressure	Pa	100	100	160	170
Motor type		DC			
Duct dimensions	mm	Φ242	Φ242	346×326	346×326
Net dimensions (WxDxH)	mm	1276×1020×388	1276×1269×388	1600×1270×540	1650×1470×540
Packed dimensions (WxDxH)	mm	1355×1045×560	1400×1370×573	1710×1410×720	1760×1610×720
Net weight	kg	58	69	151	165
Gross weight	kg	77	90	184	198
Operating temperature range	°C	-7 to 43 DB, RH 80% or lower			

**Note:**

- All models each have have 3 airflow setting.
- Sound level is measured 1.4m below the center of the unit in an semi-anechoic chamber.
- Efficiency is measured under the following conditions:  
Cooling: exhaust air temp 27°C DB, 19.5°C WB; fresh air temp. 35°C DB, 28°C WB.  
Heating: exhaust air temp 21°C DB, 13°C WB; fresh air temp. 5°C DB, 2°C WB.



# BRANCH JOINTS

Type	Appearance	Model	Packed Dimensions mm	Gross Weight kg	Note
Branch joints for outdoor units		BJC-02E-CM(i)	255×150×185	2.0	Connecting two outdoor units
		BJC-03E-CM(i)	345×160×285	4.3	Connecting three outdoor units
Branch joints for indoor units		BJF-224-CM(i)	290×105×100	0.4	/
		BJF-330-CM(i)	290×105×100	0.6	/
		BJF-710-CM(i)	310×130×125	0.9	/
		BJF-1344-CM(i)	350×180×170	1.5	/
		BJF-E1344-CM(i)	365×195×215	1.9	/
		BJF-E1500-CM(i)	390×230×255	3.1	/
		BJF-E2690-CM(i)	390×230×255	3.4	/

# Dimensions

## Indoor Branch Joints

Model	Gas side joints	Liquid side joints
BJF-224-CM(i)		
BJF-330-CM(i)		
BJF-710-CM(i)		
BJF-1344-CM(i)		
BJF-E1344-CM(i)		
BJF-E1500-CM(i)		
BJF-E2690-CM(i)		

# Dimensions

## Outdoor Branch Joints

Model	Gas side joints	Liquid side joints
BJC-02E-CM(i)		
BJC-03E-CM(i)		

# AHI CARRIER SOUTH EASTERN EUROPE

## AIR-CONDITIONING SA

---

AHI CARRIER South Eastern Europe Air-Conditioning S.A is responsible for the European activity of AHI CARRIER FZC in Central and South Eastern Europe, for the distribution and after-sales services of Carrier, Toshiba and Totaline air conditioning products\*.

Headquartered in Greece, with a subsidiary in Thessaloniki, the company has the responsibility of managing offices in:



Bulgaria

AHI Carrier HVAC Bulgaria EOOD



Romania

AHI Carrier Romania SRL



Austria

AHI Carrier GmbH



Czech Republic

AHI Carrier CZ s.r.o.

## OUR MISSION:

---

To be the number one choice of customers in air conditioning, heating, ventilation and industrial refrigeration applications throughout our region.

## OUR PURPOSE:

---

To create a comfortable and productive environment, whatever the climatic conditions, by offering solutions that ensure high quality indoor air.



turn to the experts 

# VALUES

---

## Performance and Quality:

---

We are committed in providing services and products of high quality and efficiency, to continuously strengthen our leadership. We provide durable and high-performance products that exceed the expectations of our customers.

## Innovation:

---

We constantly focus on providing innovative and reliable products and services that improve our environment and living conditions.

## Employee development:

---

The most valuable asset of our company is its people, which is why we encourage personal and professional development by investing in training. We believe in creating a working environment dominated by meritocracy, respect and diversity

## Customer Care:

---

Our customers' needs are at the heart of our interest, and we are constantly working on anticipating and satisfying them, by delivering high quality products, services and innovative solutions with a competitive edge.

## Business Practices:

---

Adhering to the highest standards of ethical and professional conduct is a firm commitment of our company. This includes the relationships we have with our customers, our suppliers, our competitors, the local communities in which we operate and, of course, our employees.

## Health & Safety:

---

Protecting the safety of our employees, customers and the environment is a fundamental value for us. We always ensure that our employees and workplaces are safe from dangers, and our products and services are safe for the consumer.

# ABOUT **AHI CARRIER FZC**

---

AHI CARRIER FZC, a joint venture created in December 2008 between Carrier Corporation and Air-Conditioning & Heating International (AHI), is Carrier's largest HVAC distribution entity (heating, ventilation & air conditioning) outside of U.S.A.

AHI CARRIER FZC is responsible for the markets of Russia, the Commonwealth of Independent States (CIS), Central and South Eastern Europe (15 countries), Oceania (15 countries), Africa (54 countries) and the Middle East (14 countries).

## **BUSINESS TERRITORY**

---



*\*Toshiba: In 1999, the Carrier Corporation formed a joint venture with Toshiba's air-conditioning division, the Toshiba Carrier Corporation. The two companies have joined forces to offer a wide range of air conditioning solutions.*

*Totaline: Distributes the widest range of HVACR accessories, consumables and tools for home and commercial applications and offers professional refrigeration solutions.*





## **AHI CARRIER SOUTH EASTERN EUROPE AIR-CONDITIONING S.A.**

### **Headquarters**

18, Kifissou Ave.  
104 42 - Athens  
GREECE  
Tel.: +30 210 6796300  
Fax: +30 210 6796390  
[www.ahi-carrier.gr](http://www.ahi-carrier.gr)

### **Thessaloniki Branch**

5, Ag. Georgioly str., Cosmos Offices  
570 01 - Patriarhiko Pileas Thessaloniki  
GREECE  
Tel.: +30 231 3080430  
Fax: +30 231 3080435

### **AHI Carrier HVAC BULGARIA EOOD**

Trade Center Europe Building 6, floor 3, office 6  
7 Iskarsko Shose Blvd., Sofia 1528  
BULGARIA  
Tel.: +35 929483960  
Fax: +35 929483990  
Email: [bginfo@ahi-carrier.com](mailto:bginfo@ahi-carrier.com)  
[www.ahi-carrier.bg](http://www.ahi-carrier.bg)

### **AHI Carrier ROMANIA SRL**

270d, Turnu Magurele str. Sector 4  
Cavar center - Bucharest  
ROMANIA  
Tel.: +40 214 050751  
Fax: +40 214 050753

### **AHI Carrier GmbH**

Andromeda Tower, Donau-City Str. 6/9  
1220 Wien, Österreich  
AUSTRIA  
Tel.: +43 1 269 969 710  
Fax: +43 1 269 969 740

### **AHI Carrier CZ s.r.o.**

Styblova 253/13,  
14900 Praha 5, Chodov  
CZECH REPUBLIC  
Tel.: +420 212 812 030  
[www.ahi-carrier.cz](http://www.ahi-carrier.cz)

The manufacturer reserves the right to change the product specifications, data and images without previous notice.  
The manufacturer is not responsible for printing mistakes.

